

Waters RCM 8x10 Operator's Manual

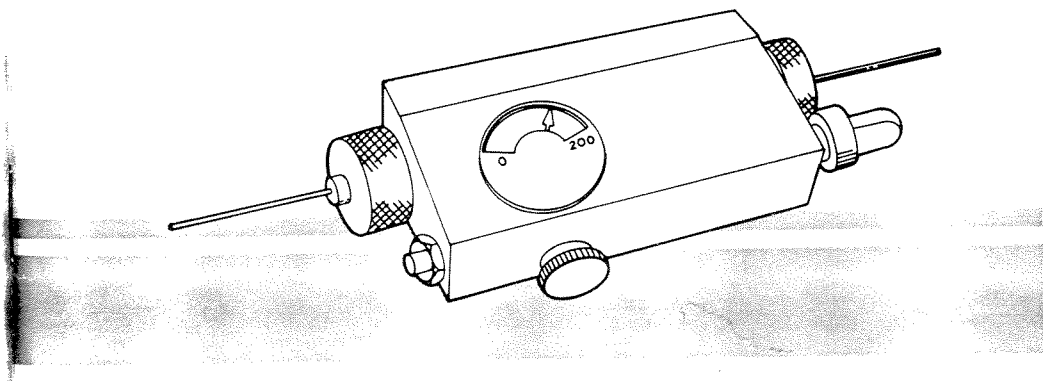

Waters

TABLE OF CONTENTS

| | | |
|----------|---|-----|
| 1 | INTRODUCTION | 1-1 |
| 1.1 | OVERVIEW | 1-1 |
| 1.2 | SPECIFICATIONS | 1-2 |
| 2 | THEORY OF OPERATION | 2-1 |
| 3 | INSTALLATION | 3-1 |
| 3.1 | UNPACKING AND INSPECTION | 3-1 |
| 3.2 | INSERTING A CARTRIDGE INTO THE RCM 8 x 10 MODULE | 3-2 |
| 3.3 | COMPRESSING THE CARTRIDGE | 3-3 |
| 3.4 | CONNECTING THE MODULE TO YOUR CHROMATOGRAPH | 3-4 |
| 3.5 | CONDITIONING THE CARTRIDGE | 3-4 |
| 3.6 | REMOVING THE CARTRIDGE | 3-5 |
| 4 | MAINTENANCE | 4-1 |
| 4.1 | TROUBLESHOOTING THE RCM 8 x 10 MODULE | 4-1 |
| 4.2 | REPLACING THE CHECK VALVE | 4-3 |
| 4.3 | REPLACING THE END FITTINGS | 4-4 |
| | APPENDIX A SPECIFICATIONS | |
| | APPENDIX B WARRANTY/SERVICE INFORMATION | |
| | APPENDIX C INSTALLING THE RCM 8 x 10 MODULE IN A | |
| | RCM-100 COLUMN HEATER MODULE | |
| | APPENDIX D INSTALLING THE RCM 8 x 10 MODULE IN A WATER | |
| | BATH | |

The information in this document is subject to change without notice and should not be construed as a commitment by Millipore Corporation. Millipore Corporation assumes no responsibility for any errors that may appear in this document. This manual is believed to be complete and accurate at the time of publication. In no event shall Millipore Corporation be liable for incidental or consequential damages in connection with or arising from the use of this manual.

NOTICE

© 1989 MILLIPORE CORPORATION, PRINTED IN THE UNITED STATES OF AMERICA. ALL RIGHTS RESERVED, THIS BOOK OR PARTS THEREOF MAY NOT BE REPRODUCED IN ANY FORM WITHOUT THE WRITTEN PERMISSION OF THE PUBLISHERS.

Waters, RCM 8 x 10, Radial-Pak, Resolve, μ Bondapak, μ Porasil, and Dextro Pak are trademarks of Millipore Corporation
RCM-100 and Nova-Pak are registered trademarks of Millipore Corporation

LIST OF TABLES

| | | |
|-----|----------------------------|-----|
| 4-1 | TROUBLESHOOTING GUIDE..... | 4-1 |
|-----|----------------------------|-----|

LIST OF FIGURES

| | | |
|-----|---|-----|
| 1-1 | RCM 8 x 10 MODULE..... | 1-1 |
| 2-1 | FLOW THROUGH A STANDARD STEEL COLUMN..... | 2-2 |
| 2-2 | FLOW THROUGH A RADIALLY COMPRESSED CARTRIDGE..... | 2-2 |
| 3-1 | RCM 8 x 10 MODULE NON-METALLIC CONNECTOR ASSEMBLY..... | 3-2 |
| 3-2 | RCM 8 x 10 MODULE STAINLESS STEEL CONNECTOR ASSEMBLY..... | 3-3 |
| 3-3 | COMPRESSING THE CARTRIDGE..... | 3-4 |
| 4-1 | RCM 8 x 10 MODULE CUTOFF VIEW..... | 4-3 |
| 4-2 | END FITTING COMPONENTS..... | 4-4 |
| 4-3 | FERRULE AND COMPRESSION ASSEMBLY..... | 4-5 |
| C-1 | INSTALLING THE RCM 8 x 10 MODULE IN THE RCM-100 COLUMN HEATER MODULE..... | C-1 |



INTRODUCTION

1.1 OVERVIEW

Waters RCM 8 x 10™ module (Figure 1-1) applies and maintains radial compression on both 5 mm and 8 mm flexible wall Radial-Pak™ High Performance Liquid Chromatography (HPLC) cartridges. This process provides a more homogeneous packed bed structure, increases column efficiency, and eliminates channeling and the formation of voids, even during high flow or rapid mobile phase changes during gradient chromatography.

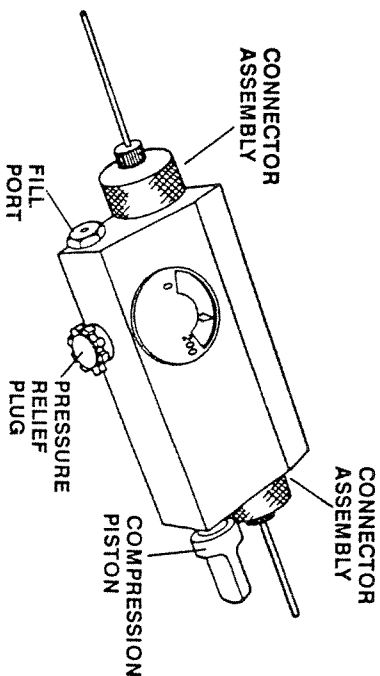

FIGURE 1-1 RCM 8 x 10 MODULE

Radial-Pak cartridges are available in a variety of packing materials and require no tools or fittings for installation in the RCM 8 x 10 module.

1.2 SPECIFICATIONS

Environmental Data

Non-metallic connectors

Operating temperature: 4 to 40 ° C

Module

Operating temperature: 4 to 70 ° C

Dimensions

Height: 1.25 inches

Length: 7.00 inches

Width: 2.15 inches

Pressure Limits

Maximum Mobile Phase Pressure: 2000 psi

Maximum Compression: 3000 psi



THEORY OF OPERATION

The RCM 8 x 10 module applies pressure along the circumference of a flexible Radial-Pak cartridge containing the packed chromatographic bed. Pressure molds the cartridge wall around the column packing, decreasing interstitial spaces within the bed. Figure 2-1 illustrates flow through a standard steel column and Figure 2-2 illustrates flow through a radially compressed cartridge.

In Figure 2-1, note that the channels near the column walls allow easier flow of the mobile phase and lead to an uneven inefficient flow profile. In Figure 2-2, note that since the column bed is tightly packed near the wall, band spreading is greatly reduced leading to high efficiency. This mechanical stabilization of the packed bed prolongs cartridge life because particles cannot move during high flow or mobile phase changes during gradient operations.

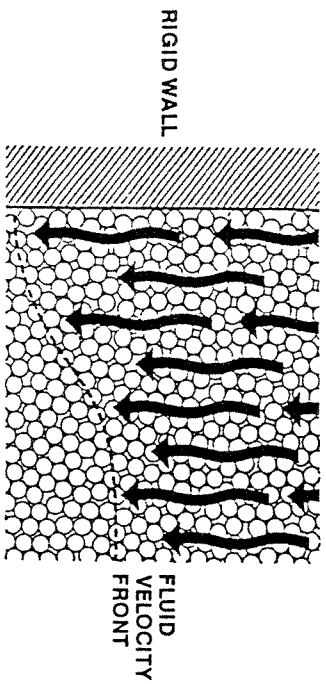

FIGURE 2-1 FLOW THROUGH A STANDARD STEEL COLUMN

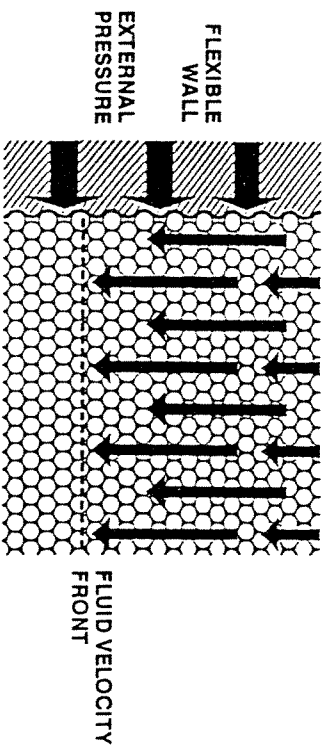

FIGURE 2-2 FLOW THROUGH A RADIALY COMPRESSED CARTRIDGE

3

INSTALLATION

3.1 UNPACKING AND INSPECTION

The RCM 8 x 10 module consists of a housing that contains a gauge, a pressure piston, a filling port, a relief plug and two end connectors (see Figure 1-1). A startup kit is included.

Unpack and check the package contents against the packing list to ensure that the shipment is complete.

Inspect all items for damage. If any content discrepancy or damage is found, immediately contact the shipping agent and Waters Chromatography Division.

3.2 INSERTING A CARTRIDGE INTO THE RCM 8 x 10 MODULE

This procedure is for the non-metallic connectors that are standard with the module. However, it is also applicable for use with the optional stainless steel connectors.

NOTE: When referring to the parts called out in Figures 3-1 and 3-2, refer to Appendix B for a listing of the associated replacement part numbers.

1. Remove the plastic caps from the RCM 8 x 10 module body. Then remove the plastic caps from each end of the two connector assemblies. These caps are used to protect the RCM 8 x 10 module from damage during shipment.

2. Check to make sure that both ends of the new cartridge and the end connectors are free from dirt particles.

3. Place the washers on each connector before inserting a cartridge (Figure 3-1).

NOTE: Refer to Figure 3-2 if you are installing the optional stainless steel connectors.

4. Push a connector into one end of the cartridge and screw it into the module. Screw the other connector into the module and tighten both connectors.

5. Check to make sure that the pressure relief plug on the front of the module is finger tight.

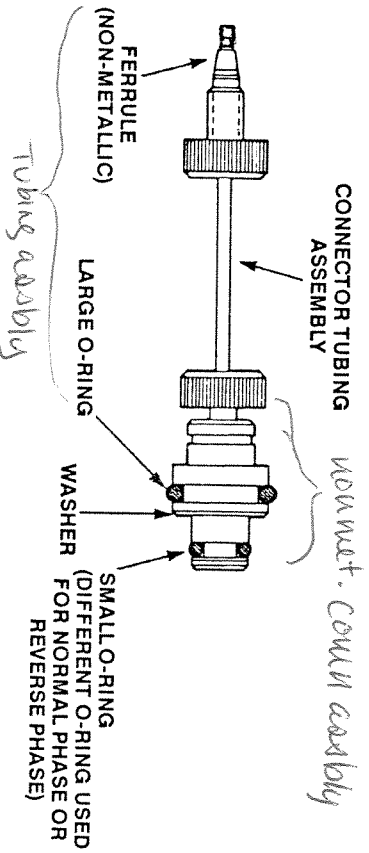

FIGURE 3-1 RCM 8 x 10 MODULE NON-METALLIC CONNECTOR ASSEMBLY
(The black cap and E-ring are not shown in the diagram.)

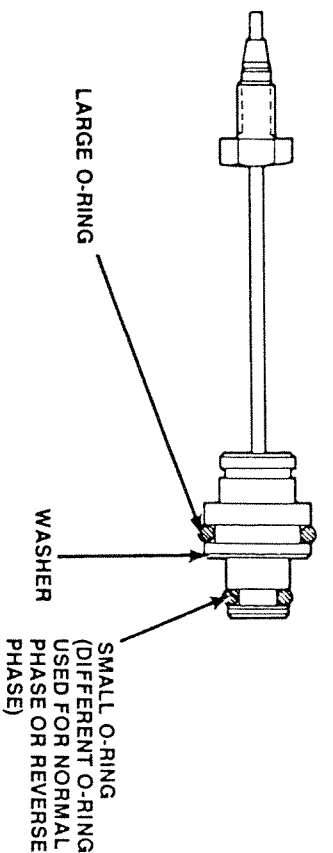

FIGURE 3-2 RCM 8 x 10 MODULE STAINLESS STEEL CONNECTOR ASSEMBLY
(The black cap and E-ring are not shown in the diagram.)

3.3 COMPRESSING THE CARTRIDGE

1. Unscrew the compression piston until 4 threads are exposed.
2. Insert a water-filled syringe into the filling port and inject water* into the module applying finger pressure. Remove the syringe.

NOTE: Use only a plastic or safety approved glass syringe. A 3 ml syringe is provided in the startup kit.

* Adding 5% methanol or isopropanol to water will prevent bacterial growth.

3. Refer to the chart included below to determine the correct operating pressure for the cartridge you wish to use, then turn the compression piston clockwise (Figure 3-3) until the pressure gauge reaches the correct level. If the piston bottoms before pressure is reached, repeat steps 1 and 2. If this does not resolve the problem, refer to Section 4.1, Troubleshooting the RCM 8 x 10 Module.

NOTE: In some RCM 8 x 10 modules, the zero position for the pressure gauge is in the middle of the red zone.

| Cartridge | Pressure |
|---|---|
| Resolve™, Nova-Pak [®] | 17 MPa (170 atm or 2500 psi, mid-green region) |
| μBondapak™, μPorasil™ + Delta-Pak (see column cont. vs.) | 5.5 MPa (55 atm or 800 psi, beginning of yellow region) |

(B)

(A)

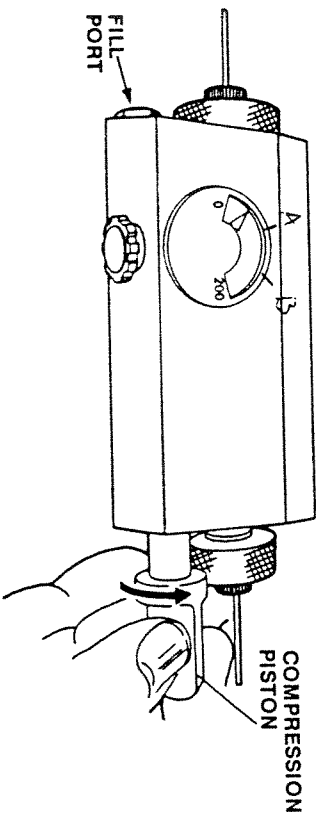

FIGURE 3-3 COMPRESSING THE CARTRIDGE

3.4 CONNECTING THE MODULE TO YOUR CHROMATOGRAPH

CAUTION

The non-metallic connectors are for use with the finger-tightened, non-metallic tubing assembly only. Using steel ferrules and/or wrench-tightening will damage the connectors.

Connect the RCM 8 x 10 module to a LC system between the detector and the injector, in the same way as a steel or glass column.

Radial-Pak cartridges can be changed while the module is connected, or a module can be dedicated for each cartridge type you use.

3.5 CONDITIONING THE CARTRIDGE

Cartridges are shipped dry. The cartridges need to be wetted with 5 to 10 column volumes of the stronger eluting component of the mobile phase before a final purge with the actual mobile phase. Equilibration between the mobile phase and the packing material is established when a stable baseline can be produced. Refer to your Radial-Pak cartridge care and use manual for equilibration information.

3.6 REMOVING THE CARTRIDGE

1. Stop the mobile phase flow.
2. Unscrew the compression piston until 4 threads are exposed.
3. Unscrew and remove one of the black end caps from the RCM 8 x 10 module. The cartridge should come out of the RCM 8 x 10 module attached to the cap. If not, unscrew the other black end cap and remove the cartridge.

FOR GENERAL LABORATORY USE
AS WELL AS
IN VITRO DIAGNOSTIC USE

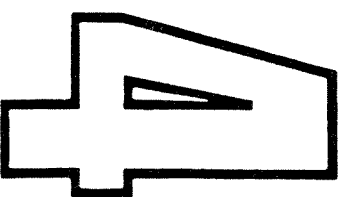

MAINTENANCE

4.1 TROUBLESHOOTING THE RCM 8 x 10 MODULE

Use the guide below for troubleshooting your RCM 8 x 10 module.

NOTE: When referring to the parts called out in the troubleshooting table outlined below, refer to Appendix B for a listing of the associated replacement part numbers.

TABLE 4-1 TROUBLESHOOTING GUIDE

| Symptom | Reason | Corrective Action |
|--|------------------------------------|--|
| Inability to achieve desired compression | Too much air in unit | Unscrew compression piston until four threads are exposed. Fill the unit with water and apply pressure on the syringe until there is considerable resistance. If the cartridge has been removed it will take around 1.5 ml of water. If the cartridge has not been removed, it may take as little as 0.1 ml water. |
| High system back pressure | Inlet or outlet connectors plugged | Hook the connector to pump and try to free the blockage with pressure or replace the connector assembly. |
| | Cartridge inlet plugged | Follow cleaning instructions found in cartridge care and use manual. |

TABLE 4-1 (CONT.) TROUBLESHOOTING GUIDE

| Symptom | Reason | Corrective Action |
|------------------------------------|--|--|
| Rapid pressure loss | Leak | Locate the source of the leak using the following Reasons/Corrective Actions: |
| | Leak at relief plug | Tighten or replace relief plug. |
| | Leak under black cap | Remove the E-ring clip from connector end and replace large O-ring*. |
| | Leak from ferrule on tube assembly | Replace ferrule (Section 4.3). |
| | Leak from compression piston | Remove piston and replace O-ring. |
| | Leak from filling port | Replace check valve inside port. *Small O-ring on connector may need to be replaced as well. |
| Slight loss of pressure with time* | Leak not visible (Fluid seeping into cartridge) | Confirm by disconnecting RCM 8 x 10 module and observing the tubing to see if liquid is seeping from the connectors. Seeping indicates that fluid is leaking into the cartridge. Perform the corrective actions outlined below: Inspect washers on connectors and replace if necessary. Check ends of cartridge for scratches; replace if necessary. (If inspection of above items reveals no problems, replace O-ring on the connectors.) Adjust piston to return pressure to desired compression range. |
| | Cartridge compressed for the first time, packed bed occasionally settles | 1. Back out compression piston to relieve pressure. 2. Tighten the relief plug. 3. Repressurize. 4. If this fails, replace the relief plug. |
| | Weep from relief plug | 1. Back out compression piston to relieve pressure. 2. Tighten the relief plug. 3. Repressurize. 4. If this fails, replace the relief plug. |

*A gradual pressure loss is normal. This can be compensated for by screwing in the compression piston (refer to Figure 4-1).

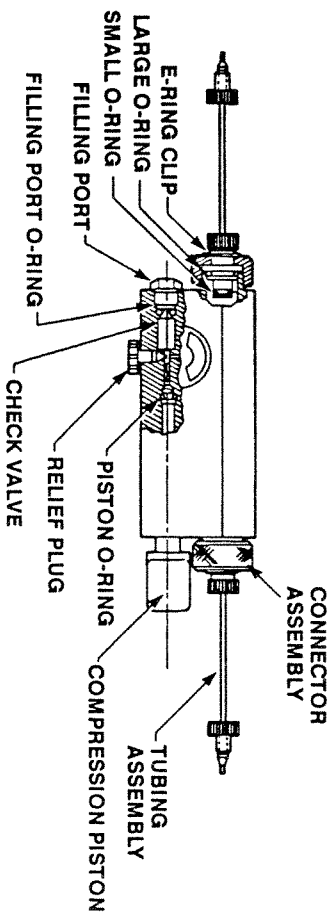

FIGURE 4-1 RCM 8 x 10 MODULE CUTOUT VIEW (NON-METALLIC CONNECTORS)

4.2 REPLACING THE CHECK VALVE

NOTE: When referring to the parts called out in this procedure, refer to Appendix B for a listing of the associated replacement part numbers.

1. Disconnect the RCM 8 x 10 module from the LC system.
2. Release compression. Back the compression piston out until the pressure drops.
3. Unscrew the filling-port adaptor by using a wrench and turning counter clockwise. Remove the filling-port adaptor.
4. Remove the O-ring with a long needle such as a dental tool.
5. Turn the RCM 8 x 10 module on its end with the filling port facing down. Tap the module on the table until the check valve drops out.
6. Rinse the cavity with water to remove any debris.
7. Insert a new check valve with the flat end toward the cavity.
8. Insert a new O-ring and center it over the end of the check valve.
9. Replace the filling port adaptor and tighten clockwise with a wrench.

4.3 REPLACING THE END FITTINGS

Perform the steps described below to cut tubing and replace the end fittings for the non-metallic connectors. The parts for the end fittings are shown in Figure 4-2.

NOTE: When referring to the parts called out in this procedure, refer to Appendix B for a listing of the associated replacement part numbers.

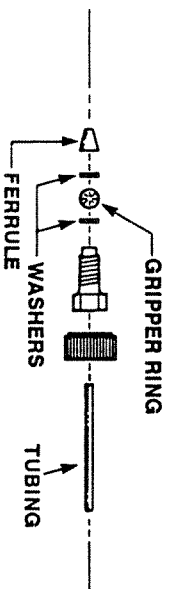

FIGURE 4-2 END FITTING COMPONENTS

Using a single-edge razor, make a cut on the plastic tubing that is straight and square. This cut is made in front of the compression screw on the worn end fitting.

To make a new compression screw assembly:

1. Slide a compression screw fitting and a washer over the end of the cut tubing.
2. Remove a gripper ring from the carrier.
3. Place the gripper ring in the top depression of the tool (Figure 4-3). Insert the end of the tubing into the gripper ring tool as far as it will go. This will seat the gripper ring at the proper length of the tubing.
4. Remove the tubing from the tool and slide the other washer and ferrule over the end of the tubing. Insert a union over the end-fitting assembly and tighten. This will seat the end-fitting assembly.

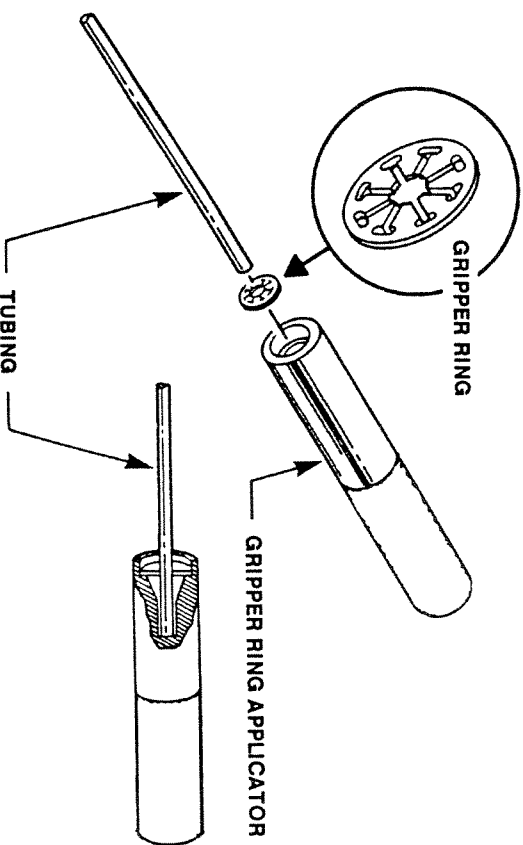

FIGURE 4-3 FERRULE AND COMPRESSION ASSEMBLY

8. Insert the end connector into the end cap and install the retainer ring.
9. Install the end-connector assembly on the RCM and tighten hand tight.
10. Connect the tubing and tighten finger tight.
11. Fill a 20-ml syringe with water and refill the RCM.
12. Pressurize the RCM and check for leaks.
13. Resume flow.

4.5 REPLACING THE PRESSURE GAUGE

1. Stop flow.
2. Release compression by unscrewing the piston all the way until it stops.
3. Place an absorbent towel under the RCM.

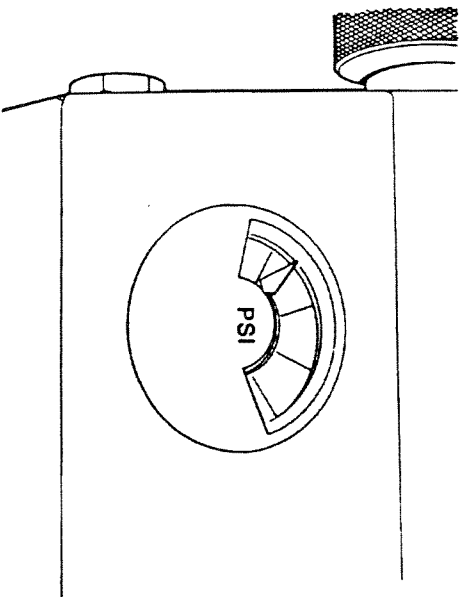

FIGURE 4-4 REPLACING THE RCM PRESSURE GAUGE

WARNING

Wear protective goggles before performing the next step.

4. Carefully break the gauge window with a small hammer and screwdriver and remove all pieces.

WARNING

The retaining ring may spring out as it is removed.

6. Use retainer ring pliers to remove the gauge retaining ring (Figure 4-5).
7. Pressurize the RCM slightly to unseat the gauge, then grasp the center of the gauge with needle nose pliers and pull it straight out of the housing (Figure 4-6).
8. Lubricate the O-ring on the new gauge, insert the gauge and orient it properly, press the gauge into place, and insert the retaining ring.
9. Fill a 20-ml syringe with water and refill the RCM.
10. Pressurize the RCM and check for leaks.
11. Place a few drops of epoxy on the edge of the new gauge window and position it on the gauge.
12. Resume flow.

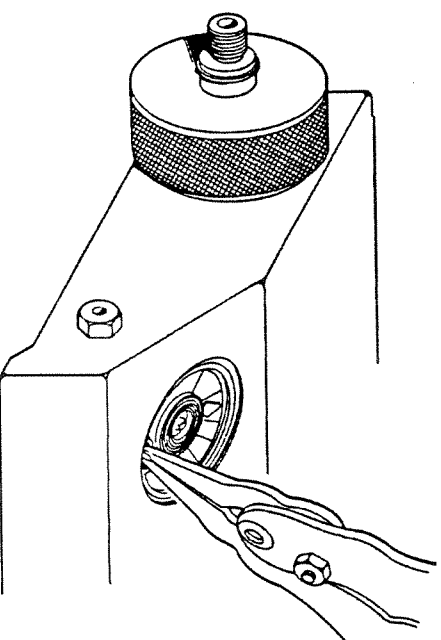

FIGURE 4-5 REMOVING THE GAUGE RETAINING RING

LIST OF ACCESSORIES (CONT)
 RADIAL-PAK CARTRIDGES

| Packing | Cartridge Dimensions | Part Number |
|--------------------------------|----------------------|-------------|
| Resolve C ₈ , 10 μm | 5 mm x 100 mm | 85672 |
| Resolve C ₈ , 10 μm | 8 mm x 100 mm | 85670 |
| Resolve Silica, 5 μm | 8 mm x 100 mm | 84634 |
| Resolve Silica, 10 μm | 5 mm x 100 mm | 84630 |
| Resolve Silica, 10 μm | 8 mm x 100 mm | 84730 |
| Resolve CN, 10 μm | 5 mm x 100 mm | 84626 |
| Resolve CN, 10 μm | 8 mm x 100 mm | 84636 |
| Dextro™ Pak Cartridge | 8 mm x 100 mm | 85650 |

WARRANTY/SERVICE INFORMATION
 Waters Service Department Message Center
 1-800-252-HP LC
 (USA only)

APPENDIX B

Serial No. _____ Startup Date _____

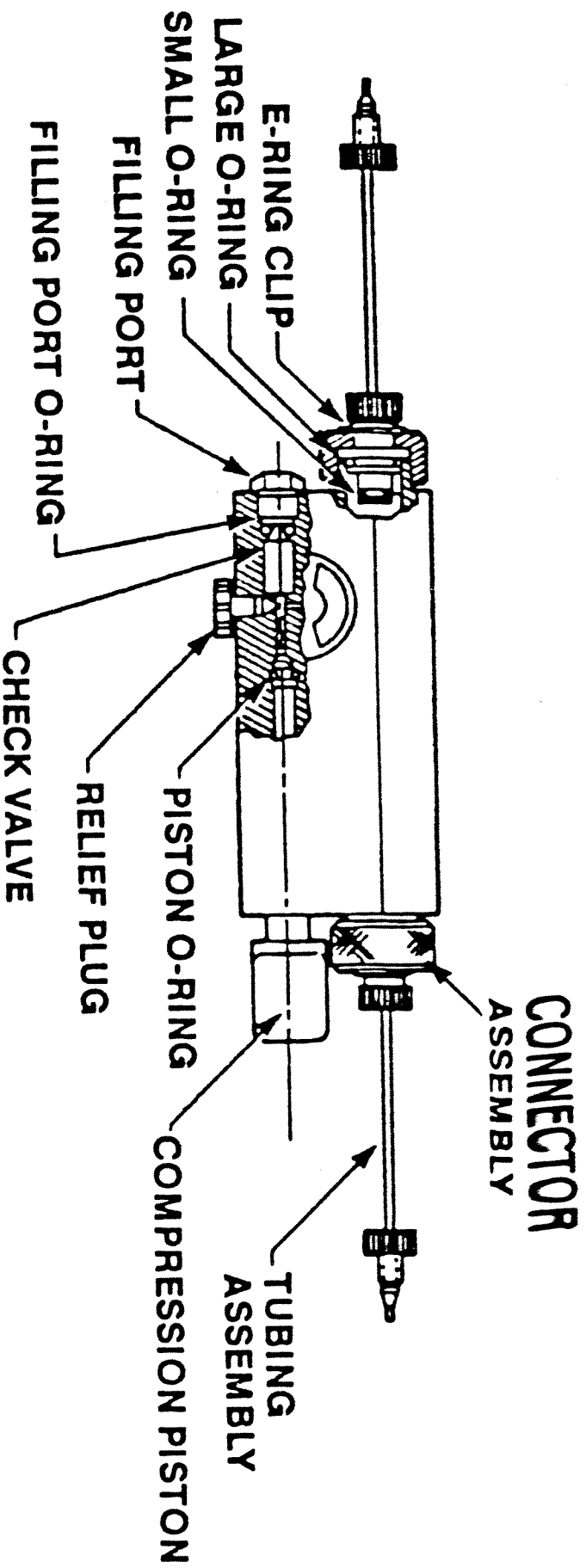

FIGURE 4-1 RCM 8 x 10 MODULE CUTOUT VIEW (NON-METALLIC CONNECTORS)

4.2 REPLACING THE CHECK VALVE

NOTE: When referring to the parts called out in this procedure, refer to Appendix B for a listing of the associated replacement part numbers.

- 1 Disconnect the RCM 8 x 10 module from the LC system.

LIST OF RECOMMENDED REPLACEMENT PARTS

| Description | Part Number |
|---|-------------|
| Non-metallic Connector Assembly | 15898 |
| Non-metallic Connector Tubing Assembly | 88919 |
| Stainless Steel Connector Assembly | 82892 |
| Pressure Piston | 88455 |
| O-ring for Piston | 88494 |
| Washer for Connectors | 88426 |
| E-ring for Connector | 82875 |
| Pressure Relief Plug | 88027 |
| Check Valve | 82888 |
| Filling Port Adapter | 88458 |
| Gauge | 84745 |
| Glass for Gauge | 84819 |
| Gauge Retaining Ring | 84746 |
| O-rings | |
| Large for Connector | 77013 |
| Small for Connector - Normal Phase | 75490 |
| Small for Connector - Reverse Phase | 15797 |
| Filling Port | 75490 |
| Pressure Piston | 88494 |
| Gripper ring replacement kit, includes | |
| 10 Gripper rings, 20 washers, 10 ferrules, tool | 21908 |
| Gripper rings, 10 | 88696 |
| Gripper ring tool | 19865 |
| Washers | 21932 |
| Ferrule, non-metallic | 88691 |

LIST OF ACCESSORIES RADIAL-PAK CARTRIDGES

| Packing | Cartridge Dimensions | Part Number |
|------------------------------------|----------------------|-------------|
| Nova-Pak C ₁₈ , 4 μm | 5 mm x 100 mm | 80100 |
| Nova-Pak C ₁₈ , 4 μm | 8 mm x 100 mm | 86342 |
| Nova-Pak Phenyl, 4 μm | 5 mm x 100 mm | 10657 |
| Nova-Pak Phenyl, 4 μm | 8 mm x 100 mm | 10658 |
| Nova-Pak CN HP, 4 μm | 5 mm x 100 mm | 10224 |
| Nova-Pak CN HP, 4 μm | 8 mm x 100 mm | 10223 |
| Nova-Pak Silica, 4 μm | 5 mm x 100 mm | 10986 |
| Nova-Pak Silica, 4 μm | 8 mm x 100 mm | 10987 |
| μ Bondapak C ₁₈ , 10 μm | 8 mm x 100 mm | 85721 |
| μ Bondapak Phenyl, 10 μm | 8 mm x 100 mm | 85722 |
| μ Bondapak NH ₂ , 10 μm | 8 mm x 100 mm | 85724 |
| μ Porasil 10, μm | 8 mm x 100 mm | 85720 |
| Resolve C ₁₈ , 5 μm | 8 mm x 100 mm | 84624 |
| Resolve C ₁₈ , 10 μm | 8 mm x 100 mm | 84720 |
| Resolve C ₁₈ , 10 μm | 5 mm x 100 mm | 84620 |