

ACQUITY UPLC Sample Manager - Flow Through Needle

Overview and Maintenance Guide

General information

Copyright notice

© 2010 – 2019 WATERS CORPORATION. PRINTED IN THE UNITED STATES OF AMERICA AND IN IRELAND. ALL RIGHTS RESERVED. THIS DOCUMENT OR PARTS THEREOF MAY NOT BE REPRODUCED IN ANY FORM WITHOUT THE WRITTEN PERMISSION OF THE PUBLISHER.

The information in this document is subject to change without notice and should not be construed as a commitment by Waters Corporation. Waters Corporation assumes no responsibility for any errors that may appear in this document. This document is believed to be complete and accurate at the time of publication. In no event shall Waters Corporation be liable for incidental or consequential damages in connection with, or arising from, its use. For the most recent revision of this document, consult the Waters website (www.waters.com).

Trademarks

ACQUITY™ is a trademark of Waters Corporation.

ACQUITY UPLC™ is a trademark of Waters Corporation.

Empower™ is a trademark of Waters Corporation.

MassLynx™ is a trademark of Waters Corporation.

THE SCIENCE OF WHAT'S POSSIBLE™ is a trademark of Waters Corporation.

TORX® is a registered trademark of Acument Intellectual Properties, LLC in the United States or other countries.

Waters™ is a trademark of Waters Corporation.

Waters Quality Parts™ is a trademark of Waters Corporation.

All other trademarks are property of their respective owners.

Customer comments

Waters' Customer Experience and Knowledge Management organization invites you to report any errors that you encounter in this document or to suggest ideas for otherwise improving it. Help us

better understand what you expect from our documentation so that we can continuously improve its accuracy and usability.

We seriously consider every customer comment we receive. You can reach us at tech_comm@waters.com.

Contacting Waters

Contact Waters with enhancement requests or technical questions regarding the use, transportation, removal, or disposal of any Waters product. You can reach us via the Internet, telephone, fax, or conventional mail.

Waters contact information

| Contacting medium | Information |
|-------------------|---|
| Internet | The Waters website includes contact information for Waters locations worldwide. Visit www.waters.com |
| Telephone and fax | From the USA or Canada, phone 800-252-4752, or fax 508-872-1990. For other locations worldwide, phone and fax numbers appear in the Waters website. |
| Conventional mail | Waters Corporation Global Support Services 34 Maple Street Milford, MA 01757 USA |

Safety considerations

Some reagents and samples used with Waters instruments and devices can pose chemical, biological, or radiological hazards (or any combination thereof). You must know the potentially hazardous effects of all substances you work with. Always follow Good Laboratory Practice (GLP), and consult your organization's standard operating procedures as well as your local requirements for safety.

Safety hazard symbol notice

The  symbol indicates a potential hazard. Consult the documentation for important information about the hazard and the appropriate measures to prevent and control the hazard.

Considerations specific to the SM-FTN



Warning: To avoid electric shock, do not remove protective panels from the device. The components within are not user-serviceable.



Warning: To avoid electric shock, observe these precautions:

- Use SVT-type power cords in the United States and HAR-type power cords, or better, in Europe. For requirements elsewhere, contact your local Waters distributor.
- Inspect the power cords for damage and replace them if necessary.
- Power-off and unplug each module before performing any maintenance operation on it.
- Connect each module to a common ground.



Warning: To avoid spinal and muscular injury, do not attempt to lift a system module without assistance.

See also: For safety considerations regarding specific system modules, consult the appropriate information on the user documentation CD.

FCC radiation emissions notice

Changes or modifications not expressly approved by the party responsible for compliance, could void the user's authority to operate the equipment. This device complies with Part 15 of the FCC Rules. Operation is subject to the following two conditions: (1) this device may not cause harmful interference, and (2) this device must accept any interference received, including interference that may cause undesired operation.

Electrical power safety notice

Do not position the device so that it is difficult to disconnect the power cord.

Equipment misuse notice

If equipment is used in a manner not specified by its manufacturer, the protection provided by the equipment may be impaired.

Safety advisories











Consult the "Safety advisories" appendix in this publication for a comprehensive list of warning advisories and notices.



Operating the device

When operating the device, follow standard quality-control (QC) procedures and the guidelines presented in this section.

Applicable symbols

The following symbols can be present on the device, system, or packaging.

| Symbol | Definition |
|---|---|
|  | Manufacturer |
|  | Date of manufacture |
|  | Confirms that a manufactured product complies with all applicable European Community directives |
|  | Australia EMC compliant |
|  | Confirms that a manufactured product complies with all applicable United States and Canadian safety requirements |
|  | Environmentally friendly use period (China RoHS): indicates the number of years from the date of manufacture until the product, or components within the product, are likely to be discarded or degrade into the environment |
|  | Consult instructions for use |
|  | Alternating current |
|  | Electrical and electronic equipment with this symbol may contain hazardous substances and should not be disposed of as general waste For compliance with the Waste Electrical and Electronic Equipment Directive (WEEE) 2012/19/EU, contact Waters Corporation for the correct disposal and recycling instructions |
|  | For indoor use only |
|  | No pushing |

| Symbol | Definition |
|---|---|
|  | Indicates the maximum load you can place on that item (for example, 10kg) |
|  | Serial number |
|  | Part number, catalog number |

Audience and purpose

This guide is intended for individuals who install, operate, or maintain the sample manager - flow through needle (SM-FTN). It gives an overview of the technology and operation of the SM-FTN.

Intended use of the SM-FTN

Waters designed the SM-FTN for use in liquid chromatography applications. The SM-FTN is not intended for use in diagnostic applications.

Calibrating

To calibrate LC systems, adopt acceptable calibration methods using at least five standards to generate a standard curve. The concentration range for standards must include the entire range of QC samples, typical specimens, and atypical specimens.

Quality control

Routinely run three QC samples that represent subnormal, normal, and above-normal levels of a compound. If sample trays are the same or very similar, vary the location of the QC samples in the trays. Ensure that QC sample results fall within an acceptable range, and evaluate precision from day to day and run to run. Data collected when QC samples are out of range might not be valid. Do not report these data until you are certain that the instrument performs satisfactorily.

EMC considerations

Canada spectrum management emissions notice

This class A digital product apparatus complies with Canadian ICES-001.

Cet appareil numérique de la classe A est conforme à la norme NMB-001.

ISM classification: ISM group 1 class B

This classification has been assigned in accordance with CISPR 11 Industrial Scientific and Medical (ISM) instrument requirements.

Group 1 products apply to intentionally generated and/or used conductively coupled radio-frequency energy that is necessary for the internal functioning of the equipment.

Class B products are suitable for use in both commercial and residential locations and can be directly connected to a low voltage, power-supply network.

EC authorized representative



| | |
|-----------|---|
| Address | Waters Corporation Stamford Avenue Altrincham Road Wilmslow SK9 4AX UK |
| Telephone | +44-161-946-2400 |
| Fax | +44-161-946-2480 |
| Contact | Quality manager |

Table of contents

| | |
|---|-----------|
| General information | ii |
| Copyright notice | ii |
| Trademarks | ii |
| Customer comments | ii |
| Contacting Waters | iii |
| Safety considerations | iii |
| Safety hazard symbol notice | iii |
| Considerations specific to the SM-FTN | iv |
| FCC radiation emissions notice | iv |
| Electrical power safety notice | iv |
| Equipment misuse notice | iv |
| Safety advisories | iv |
| Operating the device | v |
| Applicable symbols | v |
| Audience and purpose | vi |
| Intended use of the SM-FTN | vi |
| Calibrating | vi |
| Quality control | vi |
| EMC considerations | vi |
| Canada spectrum management emissions notice | vii |
| ISM classification: ISM group 1 class B | vii |
| EC authorized representative | vii |
| | |
| 1 Overview | 12 |
| 1.1 Major components | 12 |
| 1.2 Flow path through the system | 16 |
| 1.3 R θ positioning mechanism | 16 |
| 1.4 Injection system | 18 |
| 1.5 Injection mechanics | 18 |
| 1.5.1 Wash system | 19 |
| 1.5.2 Thermal system | 20 |

| | |
|---|-----------|
| 2 Preparation and operation | 21 |
| 2.1 Installation recommendations for fittings | 21 |
| 2.1.1 Assembling new fittings | 22 |
| 2.1.2 1/4-28 flangeless fitting with ferrule | 23 |
| 2.1.3 1/4-28 flangeless fitting with 2-piece ferrule | 24 |
| 2.1.4 One-piece PEEK fitting | 24 |
| 2.1.5 Stainless steel (gold-plated) fitting with long flats and 2-piece stainless steel ferrule (V-detail)..... | 24 |
| 2.2 Ventilation requirements | 26 |
| 2.3 Stacking system modules without interlocking features | 26 |
| 2.4 Stacking system modules with interlocking features | 27 |
| 2.5 Drainage system requirements | 28 |
| 2.6 Installing the waste tubing | 28 |
| 2.7 Electricity source | 30 |
| 2.7.1 Connecting to a wall electricity source..... | 30 |
| 2.7.2 Connecting to a cart's electricity source | 30 |
| 2.8 Connecting signal cables | 31 |
| 2.8.1 Input/output signal connectors | 33 |
| 2.9 Installing the optional leak sensors | 33 |
| 2.9.1 Installing the optional lower leak sensor | 34 |
| 2.9.2 Installing the optional upper leak sensor | 37 |
| 2.10 Calibrating the needle | 38 |
| 2.11 Purge solvent | 39 |
| 2.12 Wash solvent..... | 39 |
| 2.13 General purge and wash solvent guidelines | 40 |
| 2.14 Priming the sample manager | 41 |
| 2.15 Washing the needle's exterior | 42 |
| 2.15.1 Stopping a needle wash routine before it finishes | 42 |
| 2.16 Loading sample plates | 43 |
| 2.17 Observing vial and plate recommendations | 46 |
| 2.18 Sample chamber considerations..... | 47 |

| | | |
|----------|--|-----------|
| 2.19 | Choosing sample needles | 47 |
| 2.20 | Choosing extension loops | 47 |
| 2.21 | Installing and replacing extension loops | 48 |
| 2.22 | Modifying needle and extension loop configuration parameters | 50 |
| 2.23 | Choosing the sample syringe | 50 |
| 2.24 | Modifying sample syringe configuration parameters | 50 |
| 2.25 | Choosing a draw rate for the sample syringe | 51 |
| 2.26 | Choosing the needle-placement setting | 51 |
| 2.27 | Recovering maximum sample from vials | 52 |
| 2.28 | Revising a plate type | 53 |
| 2.29 | Specifying an air-gap volume | 53 |
| 2.30 | Load-ahead option | 54 |
| 2.31 | Loop-offline option | 55 |
| 2.32 | Determining when to take the needle and extension loop offline | 56 |
| 2.33 | Choosing the load-ahead and loop-offline options | 57 |
| 2.34 | Reducing carryover | 57 |
| 2.35 | Auto additions | 58 |
| 2.36 | Selecting auto dilution | 58 |
| 2.37 | Responding to a leak-sensor alarm | 58 |
| 2.38 | Diagnostic tests | 61 |
| 3 | Maintenance | 63 |
| 3.1 | Contacting Waters Technical Service | 63 |
| 3.2 | Viewing module information | 64 |
| 3.3 | Recommended maintenance schedule | 64 |
| 3.3.1 | Recommended maintenance schedule for the sample manager | 64 |
| 3.4 | Spare parts | 65 |

| | |
|---|------------|
| 3.5 Safety and handling | 65 |
| 3.6 Configuring maintenance warnings..... | 65 |
| 3.7 Replacing the leak sensor | 66 |
| 3.8 Replacing the seal..... | 68 |
| 3.9 Replacing the sample needle and needle guide | 84 |
| 3.10 Replacing the sample syringe | 98 |
| 3.11 Cleaning the injection port..... | 100 |
| 3.12 Replacing the injection-valve cartridge | 104 |
| 3.13 Cleaning the exterior of the equipment | 107 |
| A Safety advisories | 108 |
| A.1 Warning symbols | 108 |
| A.1.1 Specific warnings | 109 |
| A.2 Notices..... | 110 |
| A.3 Bottles Prohibited symbol | 111 |
| A.4 Required protection | 111 |
| A.5 Warnings that apply to all Waters instruments and devices | 111 |
| A.6 Warnings that address the replacement of fuses | 115 |
| A.7 Electrical symbols | 117 |
| A.8 Handling symbols | 118 |
| B Specifications..... | 119 |
| B.1 SM-FTN and bioSM-FTN physical specifications | 119 |
| B.2 SM-FTN and bioSM-FTN environmental specifications..... | 119 |
| B.3 SM-FTN and bioSM-FTN electrical specifications | 119 |
| B.4 SM-FTN and bioSM-FTN input/output specifications | 120 |
| B.5 SM-FTN and bioSM-FTN performance specifications | 120 |
| B.6 SM-FTN and bioSM-FTN wetted materials of construction | 126 |

1 Overview

You can submit samples for analysis on the ACQUITY UPLC system by loading microtiter plates or vials onto the rotary sample tray of the Sample Manager-Flow Through Needle (SM-FTN). Using a flow-through-needle mechanism, in which the needle is part of the high-pressure sample flow path, the sample manager injects the samples it draws from the plates and vials onto a chromatographic column. Optional extension loops (installed between the sample needle and the injection valve) increase the volume of your injections beyond that of the sample needle. Using the SM-FTN, you also can dilute injected samples (auto-dilution).

This document explains the operation of both the SM-FTN and the bioSM-FTN. For information about ordering supplies for either device, visit the Waters website (www.waters.com), or consult your Waters sales representative.

1.1 Major components

The following diagrams show the SM-FTN's major components.

Figure 1–1: Front view, with doors closed

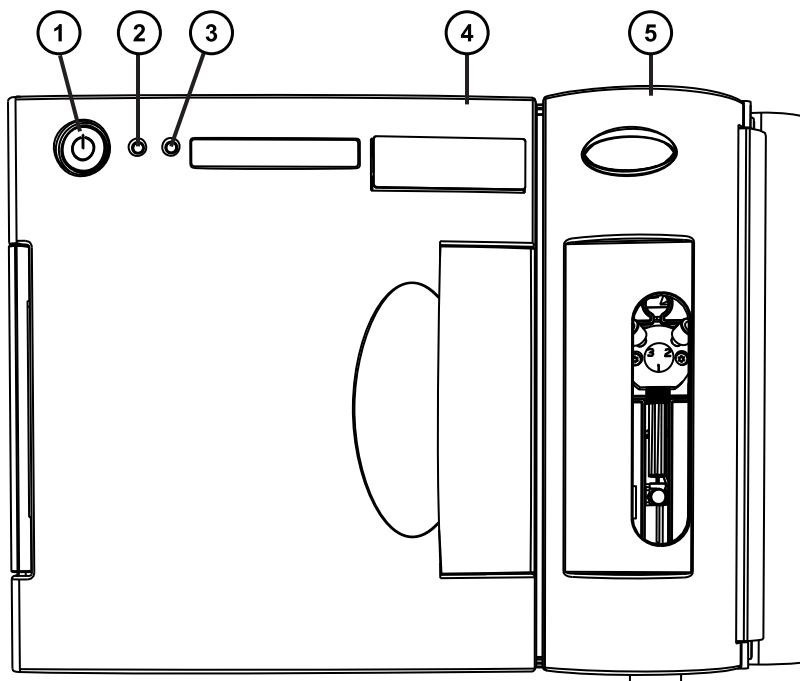

- ① On/off switch – Powers the module on and off.
- ② Power LED – Indicates the power-on or power-off status of the module. This LED is green when power is on and unlit when power is off.
- ③ Run LED – Indicates the run status. A steady green run LED indicates that injections are being run.
- ④ Sample compartment door – Allows access to sample compartment components, such as the plate selector switch and sample tray.
- ⑤ Fluidics compartment door – Allows access to components inside the fluid compartment such as the injection valve and sample syringe.

Figure 1–2: Front view, with doors open

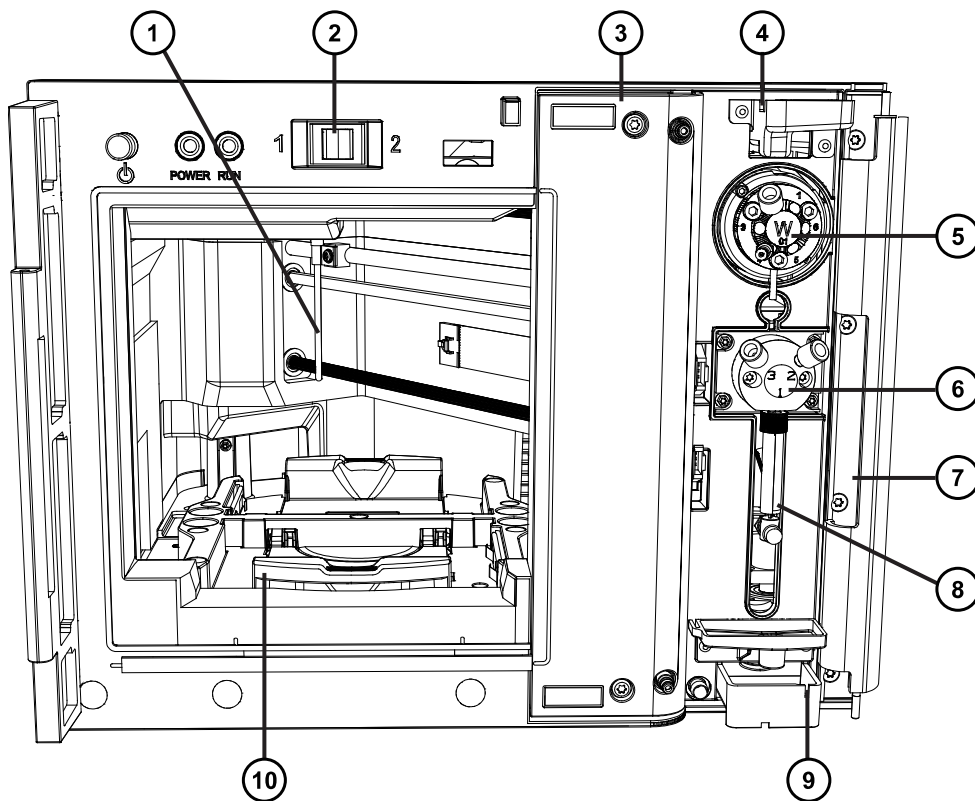

- ① Chamber temperature sensor - Located on the upper guide rail, toward the back of the sample chamber, to monitor sample environment.
- ② Plate selector switch - Toggle switch used to select plate position 1 or 2.
- ③ Access panel - Removable panel (requires a TORX driver) that allows access to sample compartment components such as the seal assembly and needle carriage.

- ④ Location of column heater leak sensor - The column heater leak sensor continuously monitors the column heater for leaks and stops the system flow when its optical sensor detects about 1.5 mL of accumulated, leaked liquid in its surrounding reservoir.
- ⑤ Injection valve - A two-position, six-port injection valve.
- ⑥ Sample syringe valve - A three-position, rotary-shear valve.
- ⑦ Location of back-pressure regulator
- ⑧ Sample syringe - Draws sample into the sample needle.
- ⑨ Location of sample manager leak sensor - The sample manager leak sensor continuously monitors the SM-FTN for leaks and stops the system flow when its optical sensor detects about 1.5 mL of accumulated, leaked liquid in its surrounding reservoir.
- ⑩ Sample tray - Secures the sample plates or vial holders in place.

Figure 1-3: Sample compartment components visible with access panel removed

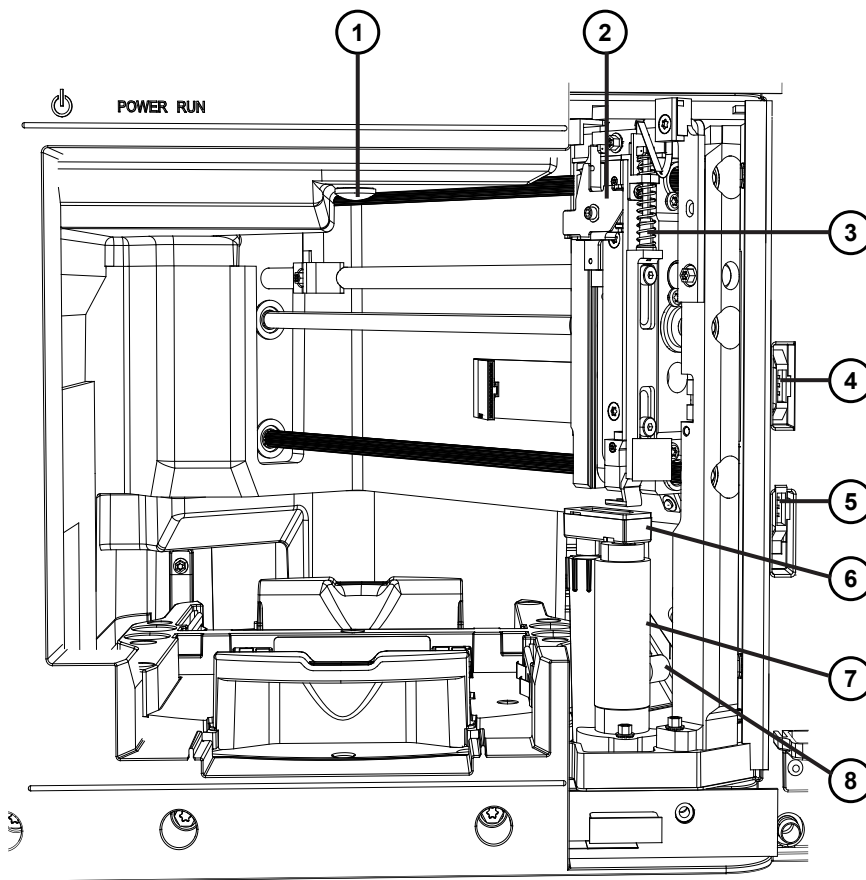

- ① Sample compartment LED lighting - The compartment light automatically switches on when the SM-FTN's sample compartment door is opened. It automatically switches off when the door is closed. The light can also be switched off via the console, to accommodate light-sensitive samples.
- ② Location of sample needle - The needle extracts sample from vials.
- ③ Sample needle carriage - Positions the sample needle in the sample compartment.
- ④ Location of the cable connector for the column-heater leak sensor.
- ⑤ Location of the cable connector for the sample-manager leak sensor.
- ⑥ Injection port wash drain - Directs the needle wash to waste.
- ⑦ Injection/wash port - Houses the injection port, needle seal, needle wash mechanism, and force sensor.
- ⑧ Location of wash tube - The wash tube delivers wash solvent to the injection/wash port.

Figure 1–4: Rear view

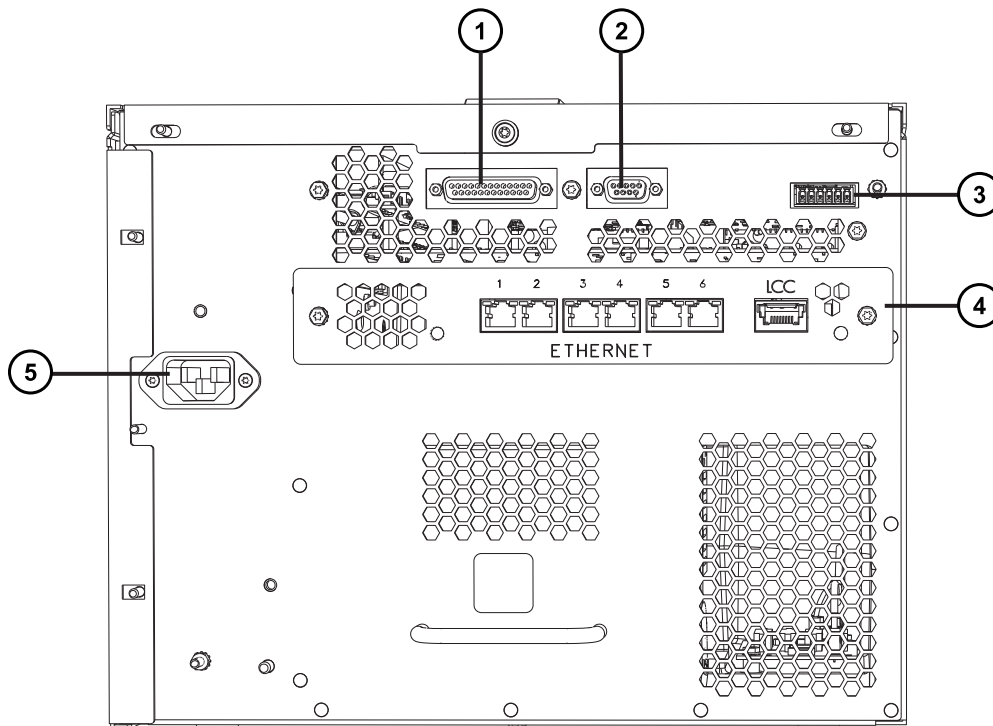

- ① Column-compartment cable connector
- ② RS-232 cable connector (for service only)

- ③ Connector for signal-cable inputs and outputs
- ④ Ethernet switch
- ⑤ Power input

1.2 Flow path through the system

The following diagram shows how the SM-FTN functions as part of the ACQUITY UPLC system.

Figure 1–5: Flow path through the system

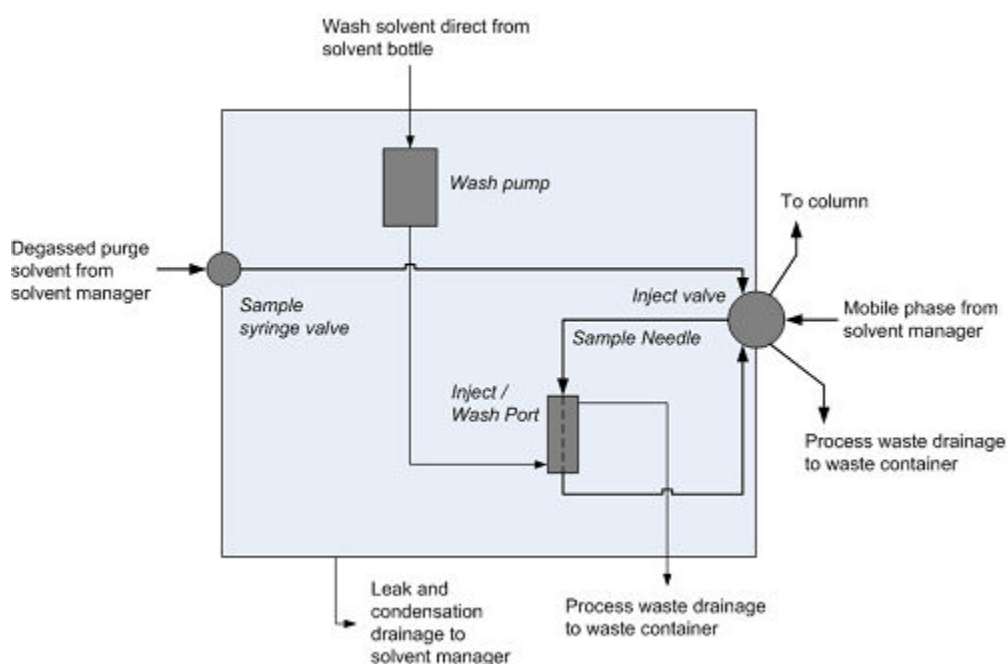

1.3 Rθ positioning mechanism

The Rθ (R-theta) positioning mechanism's two axes control the orientation of the sample plates within the sample compartment and the relative position of the sample needle carriage. The theta-rotary axis is a belt-driven shaft that rotates a pair of sample plates 360° from a reference point. The R-linear axis is the axis along which the sample-needle carriage is oriented. The carriage runs from the rear-left corner to the front-right corner of the sample compartment.

Figure 1-6: R-theta positioning mechanism, located below sample compartment

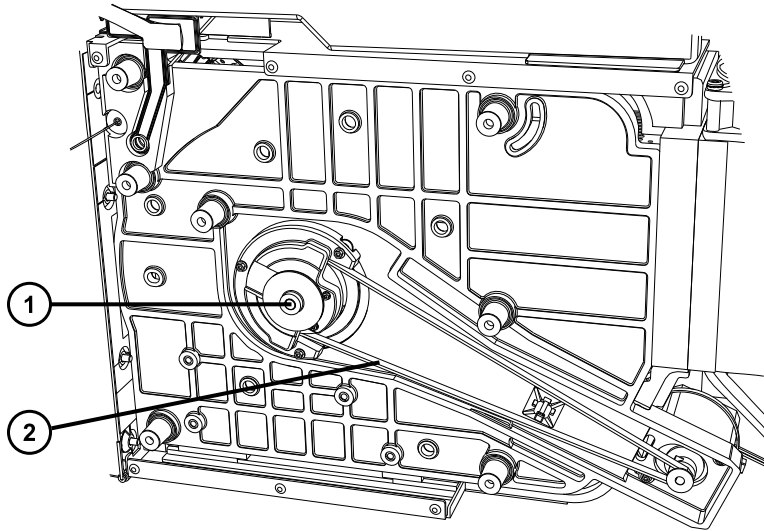

- ① Theta-rotary axis
- ② Belt

Figure 1-7: R-linear axis, located inside sample compartment

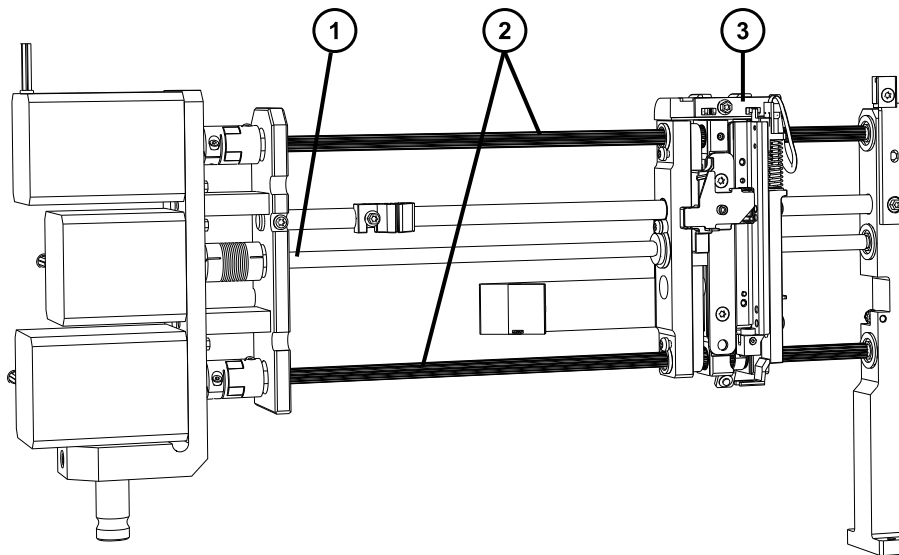

- ① R-linear axis
- ② Z and Zp axis (needle and foot/pierce needle)
- ③ Sample-needle carriage

1.4 Injection system

The injection flow path includes the assemblies required to aspirate a sample and deliver it to the column. The process involves the needle, optional extension loop, sample syringe and syringe valve, injection valve, and injection/wash port.

1.5 Injection mechanics

During an injection, this five-step sequence takes place:

1. The needle moves to the sample vial and aspirates sample from it.
2. The needle carriage inserts the needle into the injection/wash port.

Note: The entire injection port assembly rests on a spring and is guided inside a metal housing.

3. As the needle is inserted into the injection/wash port, it presses against the seat and forms a high-pressure seal.
4. The injection valve turns to start the injection.
5. The wash pump washes the outside of the needle during the injection.

Figure 1–8: Cross-view of injection needle and seal

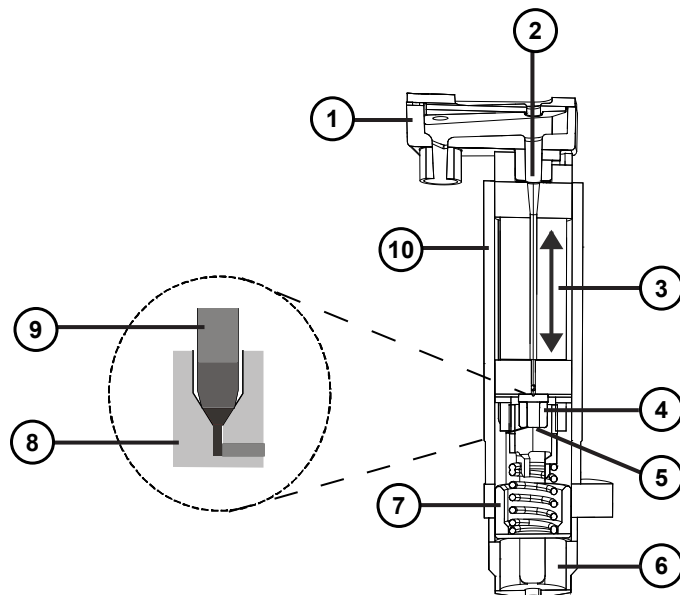

- ① Overflow cup
- ② Force applied through the needle carriage
- ③ Needle motion

- ④ Seal
- ⑤ Locking nut
- ⑥ Location of force sensor
- ⑦ Spring cup
- ⑧ Seal
- ⑨ Needle
- ⑩ Aluminum housing

The following figure shows standard-injection-mode cycle time.

Figure 1–9: Standard-injection-mode cycle time definition

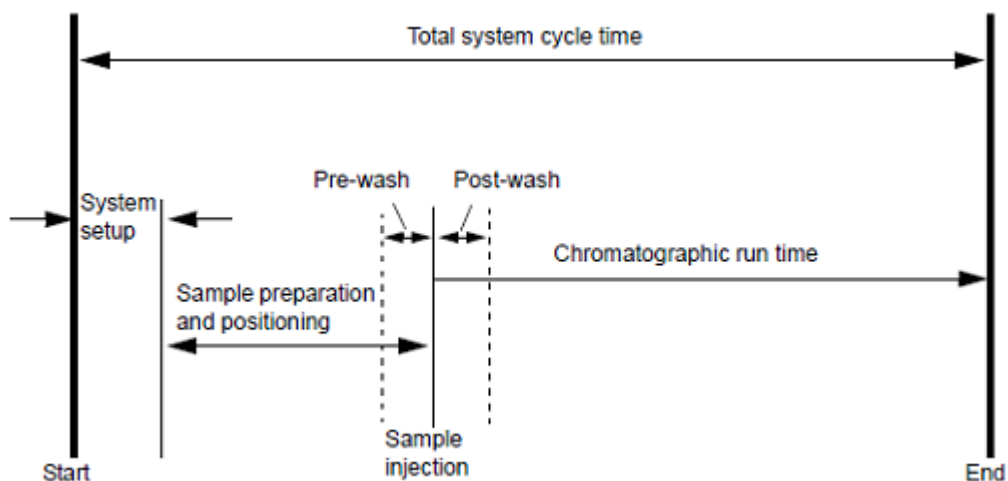

1.5.1 Wash system

The wash system cleans the exterior of the sample needle while it is inside the injection/wash port.

You can choose two external needle washes, pre-injection or post-injection. Neither wash sequence allows wash solvent to enter the sample stream.

1.5.1.1 Pre-injection (insertion) wash

The pre-injection wash washes the needle at a location above the seal position used for injection. The solvent begins to flow before the needle is lowered to this wash position.

If you are concerned about material on the outside of the sample needle damaging the seal or affecting the contact between the seal and the needle, perform the pre-injection wash, to further reduce carryover.

1.5.1.2 Post-injection, exterior needle wash

Performed by default, this wash washes the exterior of the sample needle after an injection begins and the needle is in the seal position.

1.5.2 Thermal system

The optional thermal system maintains the temperature specified for the sample compartment.

Tips:

- The sample manager's fans stop circulating air whenever the sample compartment door is open.
- The sample tray rotates slowly when the system is idle to help maintain a uniform temperature across the plates.
- Auto-defrost allows the sample manager to achieve lower operating temperatures. You can enable the auto-defrost option on the Preferences dialog box. The auto-defrost preference is recorded in the post-run report, summary report, and service profile.

2 Preparation and operation

Note: The system is shipped with a 15- μ L needle. If you are not using the default ACQUITY UPLC system configuration, which uses this needle, see [Modifying needle and extension loop configuration parameters](#).

Before you prepare the sample manager for operation, prepare the solvent manager.

Tip: For instructions explaining how to prepare the solvent manager, see the *ACQUITY UPLC Quaternary Solvent Manager Overview and Maintenance Guide* or *ACQUITY UPLC Binary Solvent Manager Operator's Overview and Maintenance Information*.



Warning: To avoid personal contamination from contact with biologically hazardous or toxic materials, before running samples,

- examine the injection valve, sample syringe, and all fittings for leaks, tightening them as necessary to stop leakage;
- ensure that the doors to both the sample compartment and fluidics compartment remain closed.

2.1 Installation recommendations for fittings



Warning: Observe Good Laboratory Practice (GLP) at all times, particularly when working with hazardous materials. Consult the Material Safety Data Sheets regarding the solvents you use. Additionally, consult the safety representative for your organization regarding its protocols for handling such materials.



Warning: To avoid personal contamination with biologically hazardous or toxic compounds, wear clean, chemical-resistant, powder-free gloves when performing this procedure.



Warning: To avoid eye injury, use eye protection when performing this procedure.

Recommendations:

- To prevent band spreading, ensure that the tubing is fully bottomed in the connection port before tightening the compression screw.
- For easier accessibility, use compression fittings with long flats to attach tubes to the injector valve.
- Perform the sample-syringe leak test whenever you replace or loosen fittings during maintenance (see the console online Help).
- Whenever you loosen fittings during maintenance, examine them for cracks, stripped threads, and deformations.
- Do not reuse stainless steel fittings more than six times.

Required tools and materials

- Chemical-resistant, powder-free gloves
- Protective eyewear

2.1.1 Assembling new fittings

For metallic (SST or MP35N) fitting and tubing assemblies with ferrules not previously assembled or set to tubing, you must mark the compression screw and connection port and ensure that the two marks line up when you tighten them.



Warning: To avoid eye injury, use eye protection when performing this procedure.



Notice: To prevent contaminating system components, wear clean, chemical-resistant, powder-free gloves when performing this procedure.

Required tools and materials

- Chemical-resistant, powder-free gloves
- Protective eyewear
- 1/2-inch open-end wrench
- 1/4-inch open-end wrench – for tightening or loosening stainless steel (gold-plated) fittings with two-piece ferrules
- Column gripping tool – for holding the column while tightening or loosening the dual-threaded fitting
- Permanent marker

To assemble the new fittings:

1. Insert the end of a tube into the hexagonal end of the compression screw.
2. Insert the tube into the larger end of the ferrule.

3. Insert the tube into the connection port.
4. Rotate the compression screw, clockwise, into the connection port until the screw is finger-tight.
5. Using a permanent marker, mark the compression screw at the 12-o'clock position.
6. Mark the connection port at the 9-o'clock position.
7. Ensure that the tubing makes contact with the bottom of the connection port, and use the 1/4-inch open-end wrench to rotate the compression screw clockwise 3/4-turn until the two marks line up.

First-use tightening:

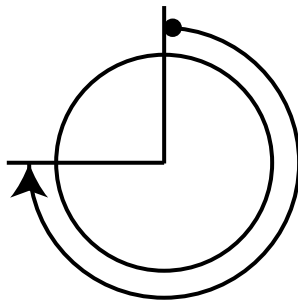

2.1.2 1/4-28 flangeless fitting with ferrule

First use or re-installed

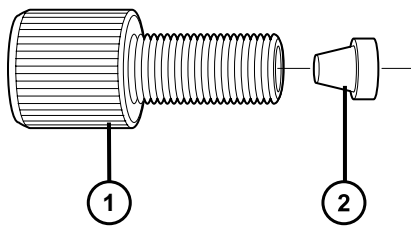

- ① Compression screw
- ② Ferrule

Tighten the fitting finger-tight.

2.1.3 1/4-28 flangeless fitting with 2-piece ferrule

First use or re-installed

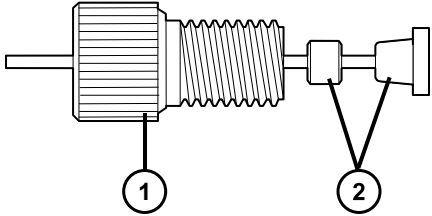

① Compression screw

② 2-piece ferrule

Tighten the fitting finger-tight.

2.1.4 One-piece PEEK fitting

Figure 2-1: First use or reinstalled

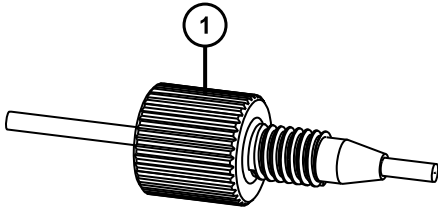

① Compression screw

Tighten the fitting finger-tight.

2.1.5 Stainless steel (gold-plated) fitting with long flats and 2-piece stainless steel ferrule (V-detail)

First use

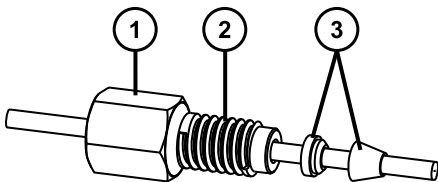

- ① Long flats
- ② Compression screw
- ③ 2-piece stainless steel ferrule

Tighten the fitting finger-tight plus an additional 3/4-turn using a 1/4-inch open-end wrench. For detailed instructions about assembling new fittings, see [Assembling new fittings](#).

Tip: To prevent band spreading, ensure that the tubing is fully bottomed in the connection port before you tighten the compression screw.

First use tightening

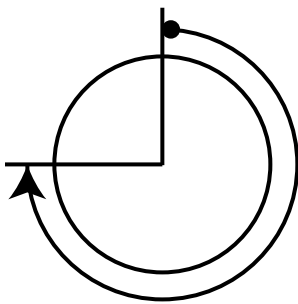

Reinstalled

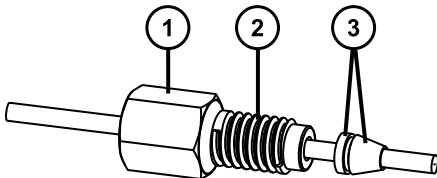

- ① Long flats
- ② Compression screw
- ③ 2-piece stainless steel ferrule

Tighten the fitting finger-tight plus as much as an additional 1/6-turn using a 1/4-inch open-end wrench.

Reinstalled tightening

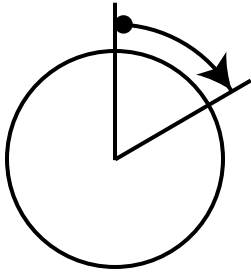

2.2 Ventilation requirements

Allow at least 15.2 cm (6.0 inches) clearance at the rear, and at least 6.4 cm (2.5 inches) clearance on the right-hand side of the sample manager for ventilation.

2.3 Stacking system modules without interlocking features

This procedure applies to system modules that are not equipped with interlocking features.



Warning: To avoid spinal and muscular injury, do not attempt to lift a system module without assistance.



Warning: To avoid crushing your fingers beneath or between modules, use extreme care when installing a module in the system stack.

To stack the modules:

1. Align the front and rear feet of the module that you are adding with the corresponding indents in the top of the chassis of the previously added module in the system stack.

Figure 2–2: Aligning feet with indents

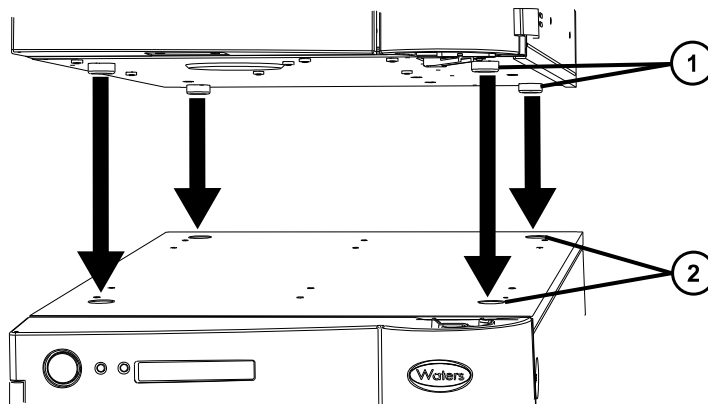

- ① Feet on underside of module being stacked
 - ② Indents on top side of previously added module
2. Carefully lower the module so that the feet rest in the indents.
- Important:** To maintain the integrity of the system stack and integrated waste system, ensure that the feet of the upper module rest in the indents of the lower module.
3. Repeat steps 1 and 2 for the remaining system modules.

2.4 Stacking system modules with interlocking features

This procedure applies to system modules equipped with interlocking features.



Warning: To avoid spinal and muscular injury, do not attempt to lift a system module without assistance.



Warning: To avoid crushing your fingers beneath or between modules, use extreme care when installing a module in the system stack.



Warning: To avoid injury, do not stack modules, including the solvent tray and rails, higher than one meter (39.4 inches) above the bench top.

To stack the modules:

1. Place the rear feet of the module that you are adding atop the previously added module in the system stack, and slide it backward until its rear alignment pin rests in the rear alignment slot on the previously added module.

Figure 2–3: Aligning pins with slots

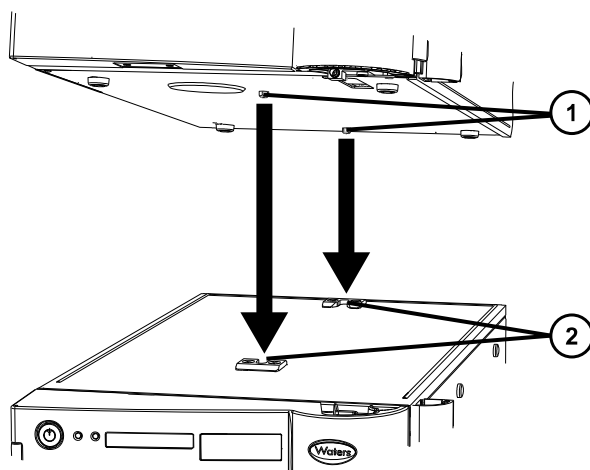

- ① Alignment pins
 - ② Alignment slots
2. Lower the front of the module that you are adding so that its front alignment pin rests in the front alignment slot on the previously added module.
 3. Repeat steps 1 and 2 for the remaining system modules.

2.5 Drainage system requirements

When plumbing the sample manager, observe these drainage system requirements:

- Ensure that the sample manager can accept drainage from the column heater, and provide a path to the waste vessel.
- Route drainage tubing and fluid lines through the tubing guide on the right-hand side of the sample manager.

2.6 Installing the waste tubing



Warning: To avoid personal contamination with biologically hazardous or toxic compounds, wear clean, chemical-resistant, powder-free gloves when performing this procedure.



Warning: To avoid eye injury, use eye protection when performing this procedure.

Required tools and materials

- Chemical-resistant, powder-free gloves
- Protective eyewear

To install the waste tubing:

1. Locate the preinstalled corrugated tubing that runs from the process waste port (found on the lower drip tray of the sample manager) and route it through the pass-through on the upper drip tray of the solvent manager.

Figure 2-4: Waste tubing routing through pass-through

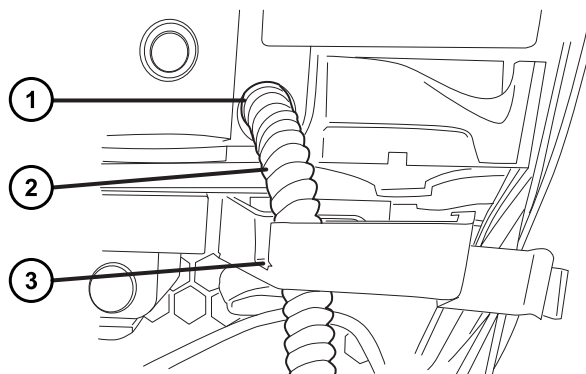

- ① Process-waste port
- ② Corrugated Teflon tubing
- ③ Pass-through on upper drip tray of solvent manager

2. Slide the adapter onto the end of the corrugated Teflon tubing.
3. Connect the adapter to the front boss fitting on the lower drip tray of the solvent manager.

Figure 2-5: Corrugated Teflon tubing connected to drip tray

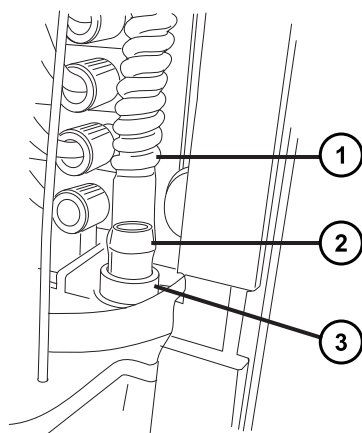

- ① Corrugated Teflon tubing
- ② Adapter
- ③ Boss fitting on solvent manager drip tray

See also: The *ACQUITY UPLC Binary Solvent Manager PLUS Overview and Maintenance Guide*, the *μBinary Solvent Manager Overview and Maintenance Guide*, or the *ACQUITY UPLC Quaternary Solvent Manager PLUS Series Overview and*

Maintenance Guide for instructions on how to route the solvent manager's waste and vent lines.

2.7 Electricity source

Most modules require a separate, grounded, power source. The ground connection in the power outlet must be common and physically close to the module.



Warning: To avoid electric shock, do not remove protective panels from the device. The components within are not user-serviceable.



Notice: To avoid damaging the electronic components of the sample manager and the column heater or column heater/cooler, always power-off the sample manager and column heater/cooler before connecting or disconnecting the interconnect cable.

2.7.1 Connecting to a wall electricity source



Warning: To avoid electric shock, observe these precautions:

- Use SVT-type power cords in the United States and HAR-type power cords, or better, in Europe. For requirements elsewhere, contact your local Waters distributor.
- Inspect the power cords for damage and replace them if necessary.
- Power-off and unplug each module before performing any maintenance operation on it.
- Connect each module to a common ground.

Note: Some column modules, such as the column heater (CH-A) and the column heater 30-cm (CH-30A), receive their power from the sample manager via the interconnect cable.

Recommendation: Use a line conditioner and uninterruptible power supply (UPS) for optimum, long-term, input-voltage stability. Contact Waters to ensure the correct selection and size.

To connect to a wall electricity source:

1. Connect the female end of the power cord to the receptacle on the rear panel of the module.
2. Connect the male end of the power cord to a suitable grounded wall outlet.

2.7.2 Connecting to a cart's electricity source

If your system includes an optional cart, follow this procedure to connect each module to a power source.



Warning: To avoid electric shock, observe these precautions:

- Use SVT-type power cords in the United States and HAR-type power cords, or better, in Europe. For requirements elsewhere, contact your local Waters distributor.
- Inspect the power cords for damage and replace them if necessary.
- Power-off and unplug each module before performing any maintenance operation on it.
- Connect each module to a common ground.

Recommendation: Use a line conditioner and uninterruptible power supply (UPS) for optimum, long-term, input-voltage stability.

To connect to a cart's electricity source:

1. Connect the female end of the cart's electrical cables (included in the start-up kit) to the receptacle on the rear panel of each system module.
2. Connect the hooded, male end of the cart's electrical cables to the power strips on its back.
3. Connect each power strip's cable to a wall outlet operating on its own circuit.

2.8 Connecting signal cables

The rear panel of the module includes a removable connector that holds the screw terminals for the I/O signal cables. The connector is keyed so that it can be inserted only one way.

Required tools and materials

- 9/32-inch nut driver
- Flat-blade screwdriver
- Connector
- Signal cable

To connect the cables:

1. Insert the connector into the connector port on the module's rear panel.

Figure 2-6: Inserting connector into connector port

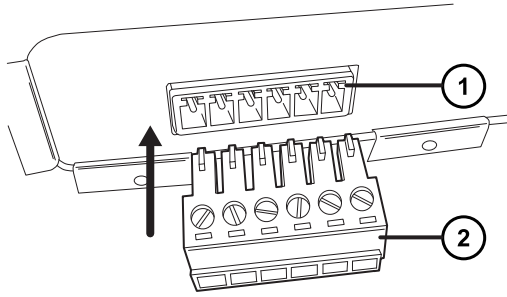

① Connector port

② Connector

2. Using the flat-blade screwdriver, attach the positive and negative leads of the signal cable to the connector.

Tip: Refer to the cable-connection label affixed to the rear panel of the module.

Figure 2-7: Positive and negative lead connections

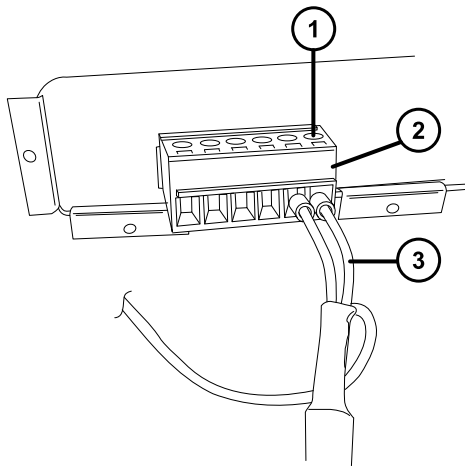

① Screw

② Connector

③ Signal cable

3. Fit the grounding cable's fork terminal on the rear-panel grounding stud and secure the terminal using the locking nut.

Note: Use the 9/32-inch nut driver to tighten the locking nut until the terminal does not move.

Figure 2–8: Grounding cable fork terminal on grounding stud

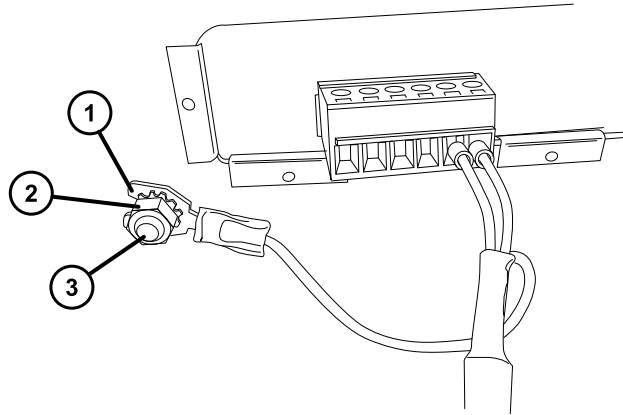

- ① Fork terminal
- ② Locking nut
- ③ Grounding stud

2.8.1 Input/output signal connectors

Refer to the cable-connection label affixed to the rear panel of the module.

Note: A contact closure output connection (Inject Start) from the sample manager is required to trigger a mass spectrometer, an ACQUITY 2996 PDA detector, or an ACQUITY ELS detector running under MassLynx software control to start.

Table 2–1: Analog-out/event-in connections

| Signal connection | Description |
|-------------------|---|
| Inject start | Indicates (with a contact closure output) that an injection has started. |
| Inject hold | Delays the next injection when the sample manager receives a contact closure input (from another system instrument, for example). |

2.9 Installing the optional leak sensors

The sample manager is fitted with two optional leak sensors, referred to as the lower and upper leak sensors.

2.9.1 Installing the optional lower leak sensor



Warning: Observe Good Laboratory Practice (GLP) at all times, particularly when working with hazardous materials. Consult the Material Safety Data Sheets regarding the solvents you use. Additionally, consult the safety representative for your organization regarding its protocols for handling such materials.



Warning: To avoid personal contamination with toxic materials, wear clean, chemical-resistant, powder-free gloves when performing this procedure.



Warning: To avoid eye injury, use eye protection when performing this procedure.

Required materials

- Chemical-resistant, powder-free gloves
- Protective eyewear
- Leak sensor

To install the optional lower leak sensor:



Requirement: Wear clean, chemical-resistant, powder-free gloves when installing the lower leak sensor.

1. Power-off the sample manager.
2. Open the fluidics compartment door.
3. Carefully unpack the new leak sensor.
4. Align the leak sensor's T-bar with the slot in the side of the leak sensor reservoir and slide the leak sensor into place.

Figure 2-9: Aligning leak sensor T-bar with slot

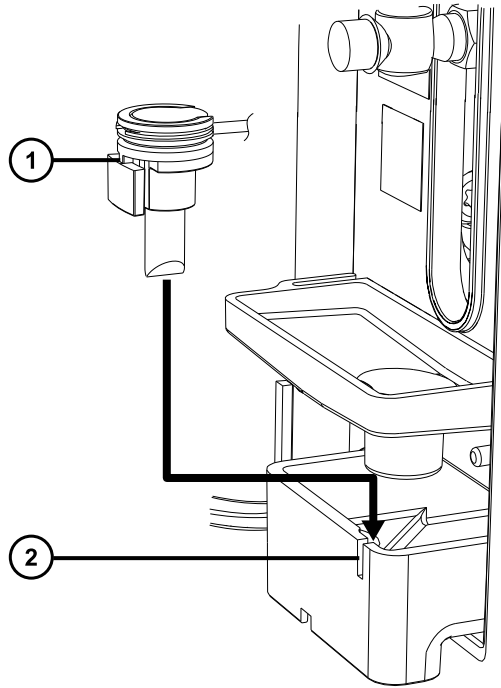

① Leak sensor T-bar

② Slot

5. Slide the leak sensor ribbon cable into the slot on the left of the leak sensor reservoir.

Figure 2-10: Leak sensor ribbon cable in slot

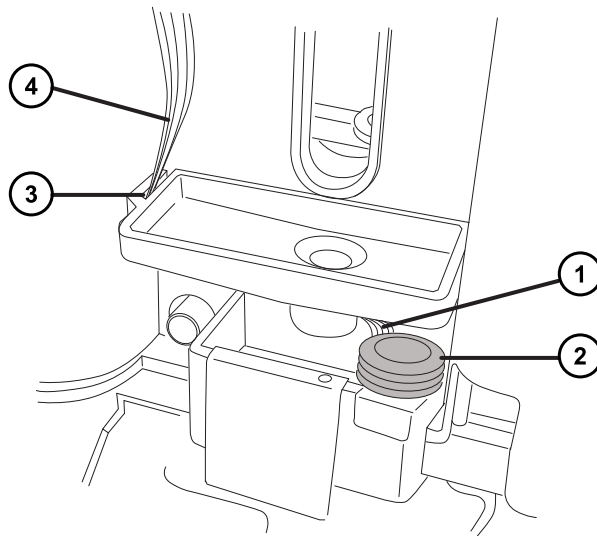

- ① Leak sensor ribbon cable
- ② Leak sensor
- ③ Slot
- ④ Leak sensor ribbon cable

Figure 2–11: Leak sensor ribbon cable routing

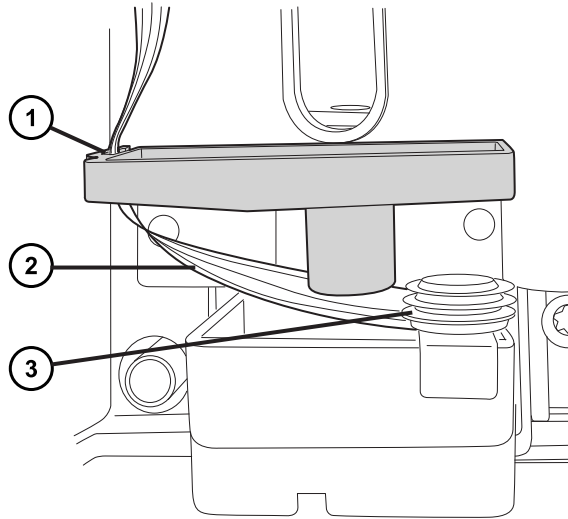

- ① Slot
- ② Leak sensor ribbon cable
- ③ Leak sensor

6. Attach the leak sensor connector to the lower port on the front of the device.

Figure 2–12: Attaching leak sensor connector

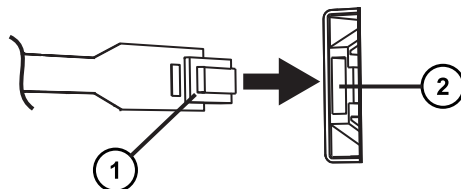

- ① Leak sensor port on front of device
- ② Leak sensor connector

7. Power-on the sample manager.

8. In the console, select **Sample Manager > Control > Reset module** to reset the sample manager.
9. In the console, enable the leak sensor (or sensors) to activate leak-detection capability (see the console online Help).

2.9.2 Installing the optional upper leak sensor



Warning: Observe Good Laboratory Practice (GLP) at all times, particularly when working with hazardous materials. Consult the Material Safety Data Sheets regarding the solvents you use. Additionally, consult the safety representative for your organization regarding its protocols for handling such materials.



Warning: To avoid personal contamination with toxic materials, wear clean, chemical-resistant, powder-free gloves when performing this procedure.



Warning: To avoid eye injury, use eye protection when performing this procedure.

Required materials

- Chemical-resistant, powder-free gloves
- Protective eyewear
- Leak sensor

To install the optional upper leak sensor:



Requirement: Wear clean, chemical-resistant, powder-free gloves when installing the upper leak sensor.

1. Power-off the sample manager.
2. Open the fluidics compartment door.
3. Carefully unpack the new leak sensor.
4. Align the leak sensor's T-bar with the slot in the side of the leak sensor, and then slide the leak sensor into place.

Figure 2–13: Aligning leak sensor T-bar with slot

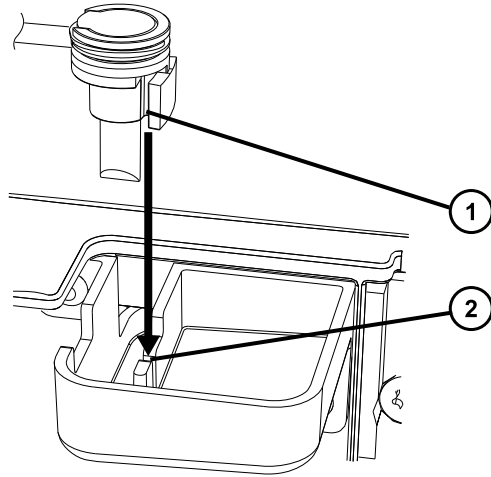

① Leak sensor T-bar

② Slot

5. Attach the leak sensor connector to the upper port on the front of the device.

Figure 2–14: Attaching leak sensor connector

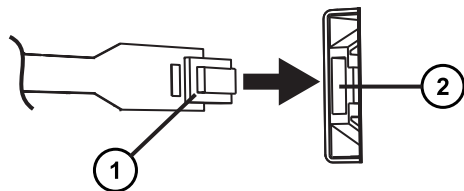

① Leak sensor connector

② Leak sensor port on front of device

6. Power-on the sample manager.
7. In the console, select **Sample Manager > Control > Reset SM** to reset the sample manager.
8. In the console, enable the leak sensor (or sensors) to activate the leak-detection capability (see the console online Help).

2.10 Calibrating the needle

You must calibrate the needle before you use the sample manager for the first time and whenever you replace the sample needle. Failing to calibrate the needle can damage it. The calibration procedure is identical for all needles.

Required tools and materials

- Business card

To calibrate the needle, do the following:

1. Open the sample manager door.
2. Remove the plates from the trays.
3. Click **Maintain > Calibrate needle**.
4. Click **Start**, and then, in the confirmation window, click **OK**.
5. Slide a business card under the needle.
6. Select 1.0 mm as the displacement per keystroke.
7. Use the **+Z** button (**Page Down** key) to drive the needle down to within one millimeter of the tray surface.
8. Switch the displacement increment to 0.1 millimeter and lower the needle until it almost touches the surface of the business card.
9. Click **Save > Yes**, and then click **Close**.
10. Remove the business card.
11. Specify the sample needle and syringe volumes, if they changed.
See also: For information about modifying the sample needle and syringe volumes, see "Modifying needle and extension loop configuration parameters" and "Modifying sample syringe configuration parameters".
12. Characterize the needle seal (see the console online Help).

2.11 Purge solvent

The primary function of the purge solvent is to move sample along the injection pathway. The purge solvent comes into contact with the sample (as the dilution solvent) only when you choose the auto-dilution option. You also use purge solvent to prime the syringe. A poorly primed syringe will adversely affect chromatographic accuracy and reproducibility.

See also: [Priming the sample manager](#)

2.12 Wash solvent

You can use wash solvent in an optional procedure that cleans the exterior of the needle before or after an injection. By default, the system washes the exterior of the needle after an injection. You can also prime the wash system with wash solvent to ascertain proper flow through the waste tubing and to confirm that the wash system is operating properly.

See also: Wash system

2.13 General purge and wash solvent guidelines

For best performance, follow these guidelines when selecting purge and wash solvents. Otherwise, you can increase the risk of carryover. The guidelines do not prohibit all other solvent combinations, however, which you can run with lower performance expectations or by manipulating injection parameters.

Use purge and wash solvents based on the sample and mobile phase chemistries of your application. When you perform auto-dilutions, ensure purge solvent and sample solutions/buffers are miscible and soluble.

For buffered aqueous, reversed-phase chromatographic conditions and MS applications, it is best to use a wash solvent of 100% methanol or acetonitrile or a mixture of methanol or acetonitrile with 0% to 20% water. Use a purge solvent with low organic content (~5% to 10%) to minimize dissolved gas while preventing microbial growth.

See the Solvent Considerations appendix in your system guide for further information about solvents.

! **Notice:** To avoid damaging the seats and seals of solenoid valves in the solvent path, do not use a nonvolatile buffer as the seal wash solvent.

For best performance when using the auto-dilution option, the purge solvent must be similar or identical to isocratic or initial-gradient conditions, excluding buffers. Do not use salt buffers in purge or wash solvents.

Table 2–2: Wash solvent effects

| Property | Effect |
|-------------------------------|---|
| Organic species | As a general principle, purge and wash solvents must include the same organic species, which is not always practicable. You can, however, use a 100% organic wash solvent. |
| Solvent composition | The purge solvent, if used for auto-dilution, must reflect as closely as possible the same composition as the initial gradient mobile phase. |
| pH | Adjust the pH of the purge and wash solvents for best peak shape and carryover performance. |
| Concentration of wash solvent | Wash solvent must be no stronger than the concentration needed to reduce carryover to an acceptable level. |
| Solubility of sample | The sample must be soluble in the purge solvent if you are performing auto-dilution. Note: Proteins (in plasma, for example) do not dissolve in solvents whose organic component is greater than 40%. |

Table 2–2: Wash solvent effects (continued)

| Property | Effect |
|----------------|---|
| Sample diluent | The purge solvent (diluent) will contact the sample, so match the sample matrix as closely as possible. To offset adverse effects on peak shape caused by the matrix’s composition, adjust the purge solvent composition. |
| Cycle times | Higher viscosity wash solvents lengthen wash cycles. |

2.14 Priming the sample manager

Priming fills the wash system with wash solvent or the injection pathway with purge solvent. You prime the system to accomplish these tasks:

- Preparing a new sample manager for operation.
- Preparing a sample manager for operation after it has been idle for more than 24 hours.
- Preparing the purge solvent.
- Changing the wash solvent.
- Removing bubbles from the lines.

Ensure that the purge and wash solvents are correctly composed, that they are LC/MS-grade, and that they are miscible with other solvents used in the system. Use filters in all solvent reservoirs, and ensure that the volumes of solvents suffice for priming.

To prime the sample syringe and wash solvent:

1. From the system view of the ACQUITY UPLC Console, select the sample manager, and then click **Control > Prime** .
Alternative: In the data application, in the control panel of the sample manager, right-click and then click **Prime**.
2. In the Prime dialog box, click the boxes on the left-hand side to select a priming function.
3. Specify a duration, in seconds, for priming the wash solvent and the number of cycles for priming the purge solvent, and then click **OK**.

Table 2–3: Priming parameter values

| Parameter | Wash solvent | Purge solvent |
|-------------------------------------|------------------|---|
| Priming range | 1 to 600 seconds | 1 to 100 cycles |
| Default priming | 15 seconds | 5 cycles |
| Recommended priming: dry inlet tube | 180 seconds | 100-µL syringe: 60 cycles 250-µL syringe: 24 cycles 500-µL syringe: 12 cycles |

Table 2–3: Priming parameter values (continued)

| Parameter | Wash solvent | Purge solvent |
|--|--------------|---|
| Recommended priming: changing solvents | 180 seconds | 100- μ L syringe: 50 cycles 250- μ L syringe: 20 cycles 500- μ L syringe: 10 cycles |

Note: Each priming cycle requires approximately 30 seconds.

When the reported system status is “Idle”, priming is finished.

2.15 Washing the needle's exterior

The wash system cleans the outside of the sample needle while it is inside the injection/wash port.

To wash the needle's exterior:

1. In the console, select the sample manager, and then click **Control > Wash Needle**.

Alternative: In the sample-manager control panel of the data application, right-click, and then click **Wash Needle**.

2. In the Needle Wash box, specify the wash duration, in seconds.

Table 2–4: Needle wash parameter values

| Solvent | Range | Default |
|--------------|-----------------|-----------|
| Wash solvent | 1 to 99 seconds | 6 seconds |

Tip: The flow rate of the wash solvent is approximately 10 to 20 mL/min, with 90:10 water/ acetonitrile. The wash flow rate varies with the viscosity of the solvent.

3. Click **OK**.

Result: The needle wash begins. When it ends, the status returns to idle.

2.15.1 Stopping a needle wash routine before it finishes

To stop a needle wash routine before it finishes:

1. In the sample manager information window, click **Control > Reset SM**.

Alternative: In the sample manager control panel of the data application, right-click, and then click **Reset SM**.

2.16 Loading sample plates

The sample manager is compatible with the ANSI standard well plates, vial trays, vials, and cap mats or sealing caps that are approved for use with the system. The sample manager holds two ANSI/SBS plates that you load through the sample-compartment door.



Warning: To avoid personal contamination with biologically hazardous or toxic compounds, wear clean, chemical-resistant, powder-free gloves when performing this procedure.



Warning: To avoid eye injury, use eye protection when performing this procedure.

Requirement: Use plates that meet ANSI/SBS standards.

Tip: Vial positions V1 through V4, located on the right-hand and left-hand sides of the sample tray, accommodate 4-mL vials. Contact Waters for inserts that allow you to use 2-mL vials in these positions.

Required tools and materials

- Chemical-resistant, powder-free gloves
- Protective eyewear

To load a sample plate:

1. Open the sample-compartment door.
2. Press the plate selector switch to select plate position 1 or 2.

Exception: If you press the plate selector switch while a diagnostic function is running, the sample manager is priming, or the sample needle is accessing the sample tray, making an injection, or being cleaned, the device beeps once and the plate position does not change. The switch operates again after the sample manager completes the task in progress.

Tip: Press the plate selector switch twice to toggle between loading a sample plate and loading positions that accept 4-mL vials.

3. Pull the sample tray out.

Figure 2–15: Pulling sample tray out of sample compartment

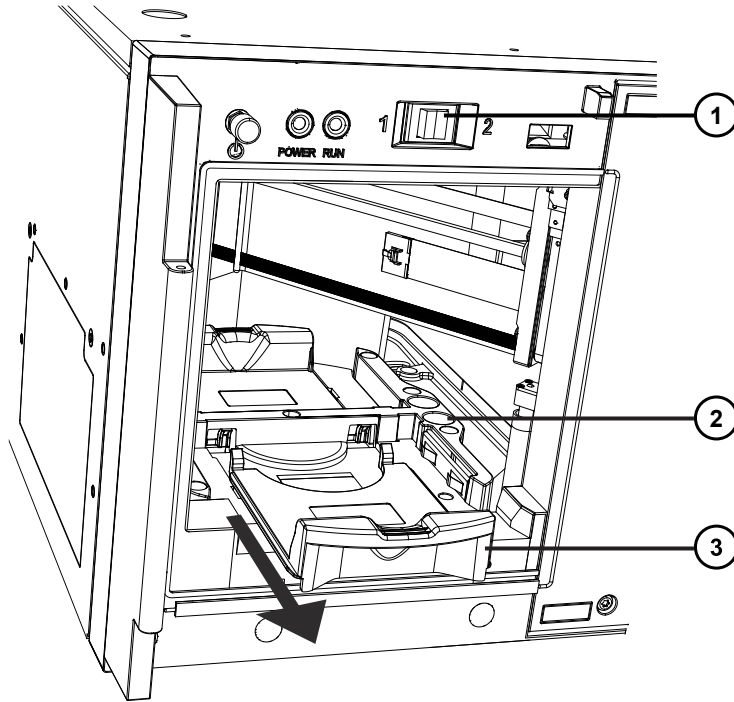

① Plate selector switch

② Position for a 4-mL vial (V1 through V4)

③ Sample tray pulled out

4. Load the plate onto the tray so that well position A,1 is at the rear, left-hand corner, and the forward edge of the plate is behind the sample tray handle.

Tip: “A” represents the row, “1” represents the vial position.

Figure 2–16: Loading sample plate onto sample tray

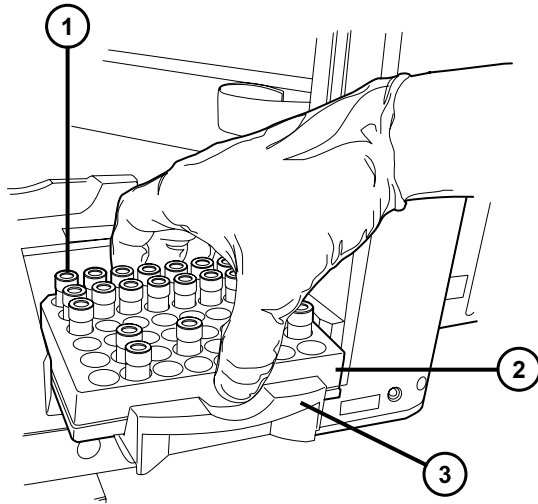

- ① Well position A,1
- ② Forward edge of sample plate
- ③ Sample tray handle

Figure 2–17: Sample plate vial positions

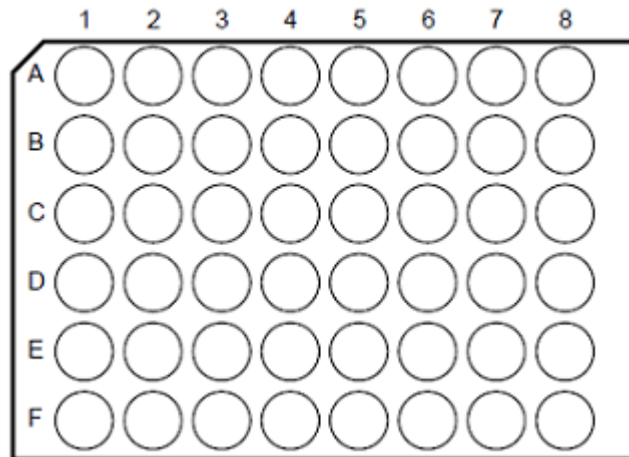

- 5. Slide the tray in until it clicks into place.

Figure 2–18: Sliding sample tray into sample compartment

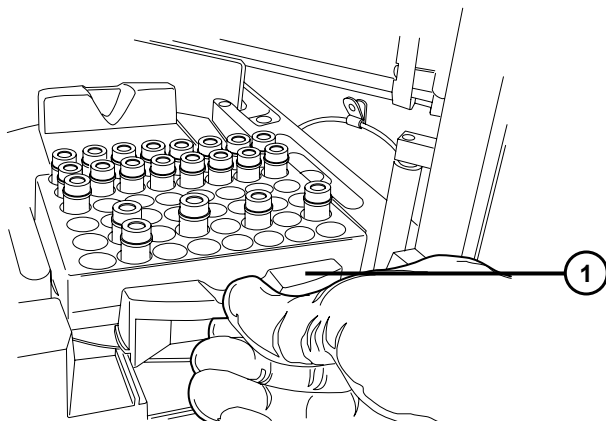

- ① Sample tray handle

! **Notice:** To avoid damaging the sample needle, the sample plates must be positioned correctly, and the sample tray must be fully engaged.

6. Close the sample-compartment door.

2.17 Observing vial and plate recommendations

Waters recommends that you observe these usage guidelines for sample vials and plates in the sample manager:

- Vials
 - Use only Waters-certified vials.
 - Ensure that vial holders conform to ANSI/SBS standards.
- Plates
 - Use only Waters-approved plates and cap mats.
 - When selecting a new plate supplier, especially for 384-well plates, measure the plate size to ensure compatibility with Waters' specifications for the sample manager.
 - To avoid warping plates, do not centrifuge them.
 - Be aware that plates containing samples with high concentrations of organic solvent can give inconsistent results at or above room temperature due to solvent evaporation.
- Covers

- Use cap-mats on sample plates whenever possible.
- Use pre-slit cap mats/seals and vial caps. Use of non-pre-slit cap mats and vial caps can cause clogging in the wash drainage lines.
- To prevent sample spillage or needle damage, use only Waters-approved covers on the sample vials.

See also: For more information about plates and vials, see the *Waters Sample Vials and Accessories Brochure* (720001818EN) or visit the [plate selector](#) and [vial selector](#) on the Waters website.

2.18 Sample chamber considerations



Warning: To avoid puncture wounds, keep hands and loose clothing clear of the needle assembly mechanism while it is moving. Note that the sample manager beeps three times whenever the sample compartment door is open, and the needle assembly mechanism is about to move.

2.19 Choosing sample needles

Waters offers multiple needle sizes, so you can choose the best option for your injection volume and sample viscosity. The 15- μ L needle provides the best injection volume accuracy, while the 30- μ L needle allows for sample aspiration rates up to four times faster.

Tip: Using a smaller needle increases cycle times.

Table 2–5: Supported sample needles for the sample manager

| Needle size | Recommended maximum injection volume |
|-----------------------|--------------------------------------|
| 15- μ L – Default | 10 μ L |
| 30- μ L | 25 μ L |

2.20 Choosing extension loops

Extension loops, which increase the volume of sample that can be drawn and held for injection, are an optional part of the injection system. You install them between the needle and the injection-valve port. The following extension loop sizes are supported:

- 50 μ L (default)
- 100 μ L

- 250 µL
- 1000 µL

Recommendation: The maximum injection volume is 75% of the total loop and needle volume. Injections larger than the recommended maximum volume can result in reduced sample recovery.

Apply the following formula to calculate the maximum injection volume:

Maximum injection volume (µL) = [loop volume (µL) + needle volume (µL)] × 0.75

Example: For a system fitted with a 250-µL loop and 30-µL needle, the maximum injection volume is 210 µL.

Maximum injection volume = [250 µL + 30 µL] × 0.75

Maximum injection volume = 280 µL × 0.75

Maximum injection volume = 210 µL

2.21 Installing and replacing extension loops



Warning: To avoid personal contamination with biologically hazardous or toxic compounds, wear clean, chemical-resistant, powder-free gloves when performing this procedure.



Warning: To avoid eye injury, use eye protection when performing this procedure.

Required tools and materials

- Extension loop kit
- Chemical-resistant, powder-free gloves
- Protective eyewear
- 1/4-inch open-end wrench

To install or replace an extension loop:

1. Power-off the sample manager.
2. Open the fluidics compartment door.
3. Using the 1/4-inch open-end wrench, unscrew the fitting of the needle tubing or extension loop from port 4 of the injection valve.

Figure 2–19: Injection valve

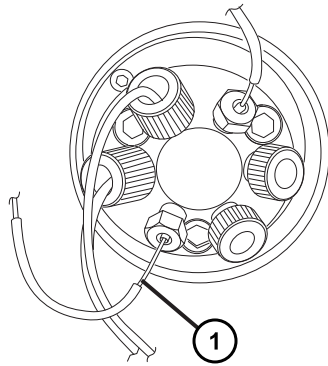

① Needle tubing (or extension loop tubing, if installed)

4. Fully insert the extension-loop tubing into port 4 of the injection valve, and then thread the fitting into the port.
5. Holding the extension loop tubing against the bottom of the port, finger-tighten the extension-loop fitting.
6. Using the 1/4-inch open-end wrench, tighten the extension-loop fitting an additional 1/6-turn (for existing fittings) or 3/4-turn (for a new fitting).

Note: Failure to properly bottom the extension loop tubing in the port can result in carryover or poor chromatography.

Figure 2–20: Extension loop

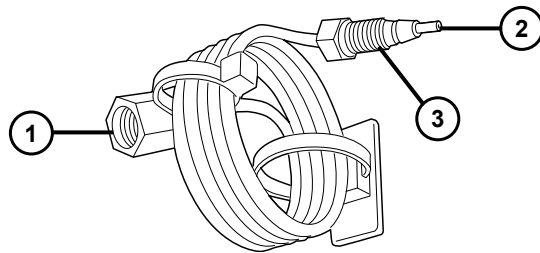

① Extension loop union

② Extension loop tubing

③ Extension loop fitting

7. Screw the sample needle's fitting into the extension-loop union, and then use the 1/4-inch open-end wrench to tighten the fitting 3/4-turn beyond finger-tight (for a new fitting) or 1/6-turn beyond finger-tight (for existing fittings).

Note: Failure to properly bottom the sample needle tubing in the extension-loop union could result in carryover or poor chromatography.

8. Close the fluidics compartment door.
9. Power-on the sample manager.
10. Modify the volume of the extension loop according to the instructions in [Modifying needle and extension loop configuration parameters](#).

2.22 Modifying needle and extension loop configuration parameters

To modify the needle or extension-loop volume setting:

1. In the console, select the sample manager, and then click **Configure > Volumes**.
2. In the Volume Configuration dialog box, select the appropriately sized needle or extension loop size from the list, and then click **OK**.

Note: If the sample manager is not fitted with an extension loop, select 0 as the loop size.

2.23 Choosing the sample syringe

The following sample-syringe sizes are available for use in the sample manager:

- 50 µL
- 100 µL – Default
- 250 µL
- 500 µL

The sample manager performs multiple draws of the syringe plunger to aspirate samples larger than the syringe volume. This repetitive action increases the time required for sample aspiration. Waters therefore recommends choosing a syringe size that can accommodate the total sample volume in the syringe (and optional extension loop).

2.24 Modifying sample syringe configuration parameters

To modify the sample syringe volume setting:

1. In the console, select the sample manager, and then click **Configure > Volumes**.
2. In the Volume Configuration dialog box, select an appropriately sized sample syringe from the list, and then click **OK**.

2.25 Choosing a draw rate for the sample syringe

The optimal draw rate for the syringe plunger depends on the volume and viscosity of the sample and the specified cycle time. Default draw rates depend on the needle size:

- 15 µL needle: 30 µL/min
- 30 µL needle: 120 µL/min

You can also specify the draw rate, in microliters per minutes, if desired.

Table 2–6: Maximum syringe draw rates

| Solvent type | 15-µL needle | 30-µL needle |
|--------------------------------|--------------|--------------|
| 50:50 methanol/water | 30 µL/min | 120 µL/min |
| 100% water | 55 µL/min | 230 µL/min |
| 100% acetonitrile | 150 µL/min | 500 µL/min |
| 100% dimethyl sulfoxide (DMSO) | 25 µL/min | 100 µL/min |

Increasing the syringe draw rate reduces the time required to aspirate sample. Note that increasing the draw rate too much results in poor area and height reproducibility. When increasing the draw rate, be sure to confirm the continued acceptability of the method.

2.26 Choosing the needle-placement setting

Needle placement is the vertical distance from the tip of the sample needle to the bottom of the sample vial. The default setting for the needle placement prevents the needle from reaching the bottom of the vial.

! **Notice:** To avoid damaging the needle, follow the guidelines in this section, ensure that the needle is calibrated, and use the appropriate needle-placement setting for your sample plates or vials.

See also: For information about calibrating the needle, see [Calibrating the needle](#).

You can change the default needle-placement setting in the software in two places: on the **Dilution** tab of the Sample Manager instrument method editor and in the Advanced Settings dialog box.

Table 2–7: Default needle-placement settings

| Plate type | Default |
|------------------|--------------------|
| 48-vial | 4.0 mm (automatic) |
| All other plates | 2.0 mm |

Note: The default needle-placement values listed in the table above represent the dimension specified by ③ in the figure below.

Figure 2–21: Sample needle in vial

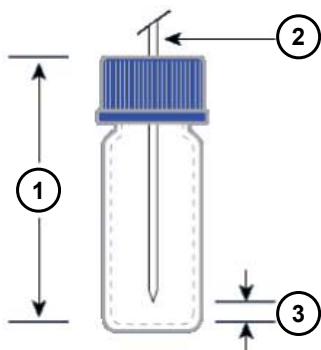

- ① Vial depth
- ② Sample needle
- ③ Distance from tip of sample needle to bottom of sample vial

2.27 Recovering maximum sample from vials

The default ANSI plate (48 vials) definition for the 2-mL Maximum Recovery Vials can leave some sample in the vial. If you must recover the maximum amount of sample, change the needle-placement setting.

See also: For information about calibrating the needle, see [Calibrating the needle](#).

Tip: To modify the needle-placement setting for vials, click **Instrument Method Editor > ACQ-FTN > General tab > Advanced**, and change the “Needle Placement (from bottom)” value.

| Vial type | Minimum needle placement (mm) | Description | Part number |
|-------------------------------------|-------------------------------|---|-------------|
| Waters Supplied Total Recovery Vial | 0.7 | Screw Cap 12 × 32 mm Clear Total Rec pre-slit PTFE/Silicone Septa | 186000385C |
| Waters Supplied Max. Recovery Vial | 2.1 | Screw Cap 12 × 32 mm Clear Max Rec pre-slit PTFE/Silicone Septa | 186000327C |
| | | Screw Cap 12 × 32 mm Amber Max Rec pre-slit PTFE/Silicone Septa | 186003886C |

| Vial type | Minimum needle placement (mm) | Description | Part number |
|----------------------------------|-------------------------------|--|-------------|
| Waters Supplied Flat Bottom Vial | 0.1 | Screw Cap 12 × 32 mm Clear with pre-slit PTFE/Silicone Septa | 186000307C |
| | | Screw Cap 12 × 32 mm Amber pre-slit PTFE/Silicone Septa | 186000847C |
| | | Screw Cap 12 × 32 mm 750 µL PP pre-slit PTFE/Silicone Septa | 186002636 |
| | | Screw Cap 12 × 32 mm 300 µL PP pre-slit PTFE/Silicone Septa | 186002639 |

See also: Waters Sample Vials and Accessories brochure on www.waters.com.

2.28 Revising a plate type

The ANSI-48Tube0.65mLHolder plate type is defined in Empower software so that the needle does not use sample near the bottom of the vial, greatly increasing the residual volume. The plate type contains 0.65-mL tubes.

To create a new plate type and modify the depth value:

1. In Empower software, open the Configure System window.
2. From the Empower Configuration tree, select **Plate Types**.
3. Select the plate type **ANSI-48Tube0.65mLHolder**.
4. From the menu, select **File > Properties**.
5. Under Plate Type, type a suitable name for the plate.
6. Change the Depth parameter to 28.5.
7. Click **OK**.

Result: A copy of the plate definition is created with a new name and revised needle depth.

2.29 Specifying an air-gap volume

Air gaps can limit sample dispersion. The default air gap is 0.

You can modify the air gap size in the sample manager instrument method, as in the following circumstances:

- To protect the sample when the injection volume is very close to the maximum recommended injection volume, add a pre-aspirate air gap. For example, you can add a pre-aspirate air gap when planning injections of 10 μL with a standard 15- μL needle.
- To protect very small sample injection volumes (1 μL or less), add to the post-aspirate air gap.
- To prevent loss of sample from the end of the needle, add a post-aspirate air gap of 0.1 to 0.2 μL .

Waters does not recommend adding air gaps before or after the sample. An air gap of 3 μL or greater causes an extra peak in the chromatography.

To specify an air-gap volume:

1. Select the sample manager instrument method.
2. Click the **General** tab, and then click **Advanced**.
3. In the Advanced Settings dialog box, click **Air Gaps**.
4. Specify a pre-aspirate or post-aspirate value, in μL .
5. Click **OK**.

Result: The  symbol appears on the **General** tab next to **Advanced**, signifying that the Advanced settings were altered.

2.30 Load-ahead option

The load-ahead option causes the sample manager to aspirate the next sample in a sample list while a current sample is running, reducing the overhead time (time in addition to the chromatographic analysis time) of an injection cycle. In many applications, the load-ahead option reduces cycle time without degrading chromatographic performance.

Restriction: You cannot use the load-ahead option on the first injection of each sample line in a sample set.

Requirement: You must take the needle and optional extension loop off-line when you use the load-ahead option.

The following figure shows standard injection mode cycle time.

Figure 2–22: Standard injection mode cycle time definition

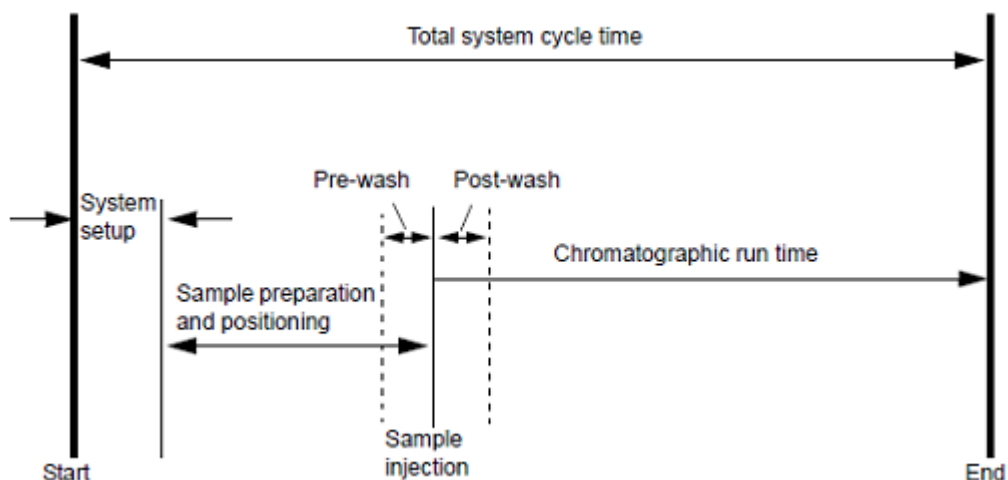

The following figure shows load-ahead mode cycle time after the first injection.

Figure 2–23: Load-ahead mode cycle time definition

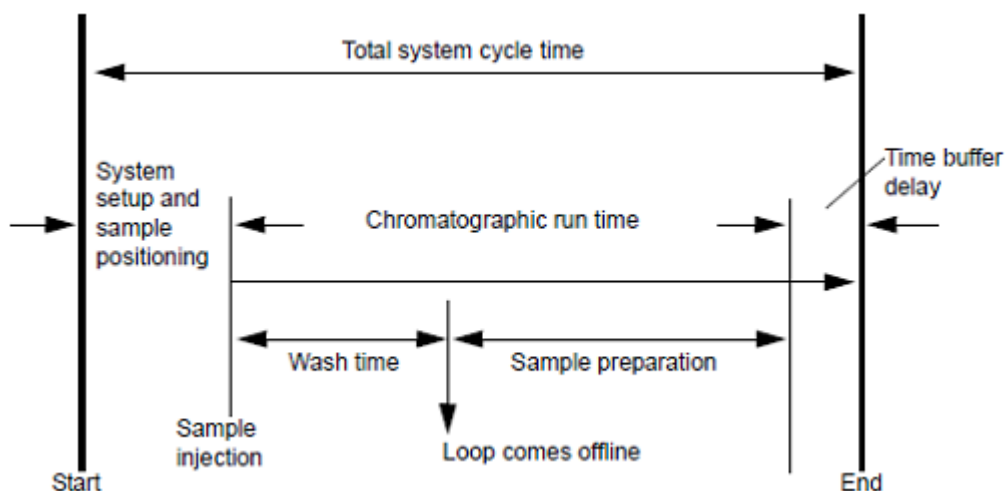

Tip: The time buffer delay is a “wait time” that compensates for variations in the time required to load a sample.

If the wash time and the sample-preparation time are equal to or greater than the chromatographic run time, then choosing the load-ahead option does not improve the cycle time.

2.31 Loop-offline option

In addition to its use with the load-ahead feature, the loop-offline option can reduce the delay volume by taking the needle and extension loop offline before the gradient reaches the injection valve and after the sample transfers to the injection port. However, delay volume is significant only in systems that use extension loops larger than 50 μL .

Take the loop offline before the first gradient change reaches the injection valve or after the gradient returns to the initial conditions.

2.32 Determining when to take the needle and extension loop offline

When the needle and extension loop are eliminated from the flow path, they contain the mobile phase composition. Solutes that deposit in the needle and extension loop because of poor solubility are not transferred to the column until the gradient composition dissolves the sample and flushes it onto the column. At that point, the solute's high-retention factor (k') causes it to elute from the column in one column volume. Choosing the correct time to take the needle and extension loop offline ensures that all of the sample is flushed from the loop.

If you are taking the needle and extension loop offline before the first gradient change, ensure that you first completely flush the sample onto the column. To do so, use solvent at the initial gradient composition. The volume of solvent must be at least five times the injection volume.

Apply this formula to calculate the extension time:

$$\text{Loop offline time (min)} = \frac{\text{Sample volume } (\mu\text{L})}{\text{Flow rate } (\mu\text{L/min)}} \times 5$$

Example: For a flow rate of 500 μL per minute, with a 20- μL loop installed, the loop offline time should be at least 0.20 minutes.

$$\text{Loop offline time (min)} = \frac{20 (\mu\text{L})}{500 (\mu\text{L/min})} \times 5$$

$$\text{Loop offline time (min)} = .04 \times 5$$

$$\text{Loop offline time (min)} = 0.20 \text{ min}$$

If you are taking the needle and optional extension loop offline after the end of the gradient, ensure that they are completely filled with solvent of the initial gradient composition before taking them offline.

In addition, observe these considerations when determining the correct needle and loop offline time:

- If the wash solvent time is longer than the loop offline time, the needle is not taken offline until the needle wash is complete.
- The needle and extension-loop offline time must not occur if their contents are of a higher concentration than the initial gradient conditions.

Tip: A programmed gradient typically flows through all parts of the instrument that contact the sample. If you initiate the needle and extension-loop offline option before the gradient reaches its final conditions, the highly organic portion of the gradient does not pass through the needle. As a

result, the gradient can fail to remove all sample from the needle, resulting in low sample recovery and an increased risk of carryover.

2.33 Choosing the load-ahead and loop-offline options

To choose the load-ahead and loop-offline options:

1. In the instrument method editor, click the **ACQ-FTN** tab, and then click the **General** tab.
2. Select the check boxes for the load-ahead and loop-offline options.
3. Specify an interval for the loop-offline option.

Tip: A programmed gradient typically flows through all parts of the instrument that contact the sample. If you initiate the needle and extension-loop offline option before the gradient reaches its final conditions, the highly organic portion of the gradient does not pass through the needle. As a result, the gradient may fail to remove all sample from the needle, resulting in low sample recovery and an increased risk of carryover.

2.34 Reducing carryover

In a chromatographic system, any substance that creates unwanted peaks or excessive background noise is contamination. Carryover, a specific type of contamination, occurs when sample material remaining in the system after an injection appears as peaks in subsequent injections, compromising quantification. To optimize system performance, carryover must be minimized and held to an acceptable level (often below the limits of detection).

Carryover can result from incorrectly installed tubing, fittings, or other hardware or by ineffective wash solvents. Take these actions to reduce carryover:

- Restrict extension-loop usage to one system.
- Ensure all tubing connections are properly seated. Tubing must seat properly (without internal gaps) inside fittings before you tighten the fittings. Poorly seated connections create reservoirs of unnecessary space that retain sample, increasing carryover.
- Inspect the needle guide for sample residue or debris, which can cause carryover. If necessary, clean or replace the guide.
- Avoid plate or vial sealing systems that use sticky substances, which can cause carryover.
- If you suspect sample interaction with the needle material, increase the strength of the wash solvent, or increase the wash time. If carryover persists, replace the needle with one of a different material composition, such as the Bio (MP35N) needle, which can reduce sample interaction.
- Follow the guidelines that appear in [General purge and wash solvent guidelines](#) when selecting wash solvents.

See also: For more information about controlling contamination in chromatographic systems, see the *Controlling Contamination in LC/MS Systems Best Practices* (715001307) on the Waters website.

2.35 Auto additions

If you use Empower 3 to control the sample manager, you can use the Auto additions function to make an injection composed of sample from as many as 10 vials, one of which is the sample vial. You can specify a delay time, to allow the sample to mix after sample from all vials is in the needle and extension loop.

Requirement: The total volume of an Auto additions injection must be less than the sample loop volume.

See also: Empower 3 online Help for additional information about using the Auto additions function.

2.36 Selecting auto dilution

Choose the auto-dilution option to dilute dissolved samples (containing no solids) using a solvent that the sample syringe delivers. You can specify an interval, to allow time for sample mixing.

To choose the dilution option:

1. In the instrument method editor, click the **ACQ-FTN** tab and then the **Dilution** tab.
2. Select the box to enable dilution.
3. Specify a needle height, purge-solvent volume, and a post-dilution delay interval.

2.37 Responding to a leak-sensor alarm

The sample manager is fitted with two leak sensors, bottom and top, referred to as the lower and upper leak sensors.

After approximately 1.5 mL of liquid accumulates in the leak-sensor reservoir, an alarm sounds indicating that the leak sensor detected a leak.



Warning: To avoid personal contamination with biologically hazardous or toxic compounds, wear clean, chemical-resistant, powder-free gloves when performing this procedure.



Warning: To avoid eye injury, use eye protection when performing this procedure.

- !** **Notice:** To avoid scratching or otherwise damaging the leak sensor,
- do not allow buffered solvents to accumulate and dry on it;
 - do not submerge it in a cleaning bath.

Required tools and materials

- Chemical-resistant, powder-free gloves
- Protective eyewear
- Cotton swabs
- Nonabrasive, lint-free wipes

To respond to a leak-sensor alarm:

1. Open the sample manager's fluidics compartment door.
2. In the console's Leak Sensors dialog box, determine which of the sample manager's two leak sensors detected a leak.
3. If the message reads "Leak Detected", locate the source of the leak and make the repairs necessary to stop it. For additional information, see the *ACQUITY UPLC Column Heater-Active Overview and Maintenance Guide*, *ACQUITY UPLC 30-cm Column Heater-Active Overview and Maintenance Guide*, *ACQUITY UPLC 30-cm Column Heater/Cooler Overview and Maintenance Guide*, or *ACQUITY UPLC Column Manager - Active and Column Manager - Auxiliary Overview and Maintenance Guide*.

- !** **Notice:** To avoid damaging electrical components and circuitry, do not disconnect an electrical assembly while electrical power is applied to a module. To completely interrupt power, set the on/off switch to the "off" position, and then disconnect the power cord from the ac source. Wait 10 seconds before disconnecting an assembly.

4. Power-off the sample manager.

- !** **Notice:** To avoid damaging the leak sensor, do not grasp it by the ribbon cable.

5. Remove the leak sensor from its reservoir by grasping the sensor by its serrations and pulling upward.

Figure 2–24: Leak-sensor assembly

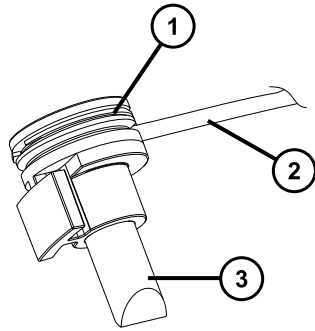

- ① Serrations
- ② Ribbon cable
- ③ Prism

Tip: If you cannot easily manipulate the leak sensor after removing it from its reservoir, detach the connector from the front of the device (see [Replacing the leak sensor](#)).

6. Use a nonabrasive, lint-free wipe to dry the leak-sensor prism.
7. Roll up a nonabrasive, lint-free wipe and use it to absorb the liquid from the leak-sensor reservoir and its surrounding area.

Figure 2–25: Leak-sensor reservoir

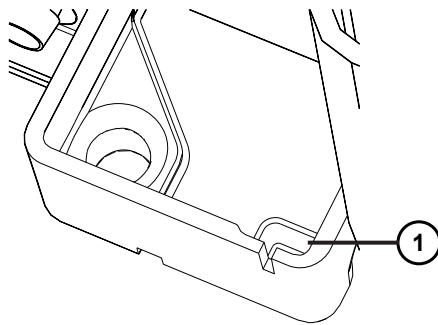

- ① Leak-sensor reservoir

8. With a cotton swab, absorb any remaining liquid from the corners of the leak-sensor reservoir and its surrounding area.
9. Align the leak sensor's T-bar with the slot in the side of the leak-sensor reservoir and slide the leak sensor into place.

Figure 2–26: Aligning lower leak sensor T-bar with slot

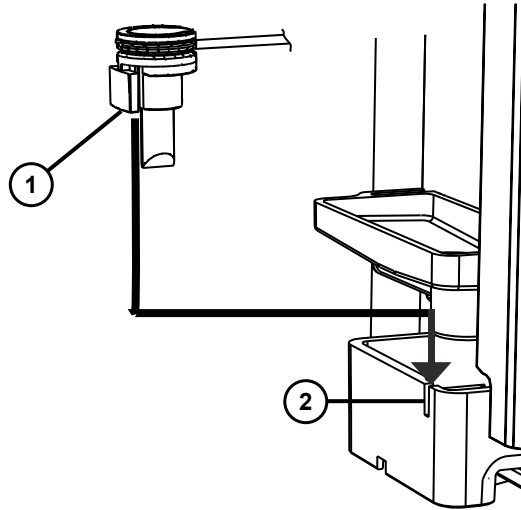

- ① T-bar
- ② Slot in leak-sensor reservoir

10. If you detached the connector from the front of the device, reattach it.

Figure 2–27: Attaching leak sensor connector

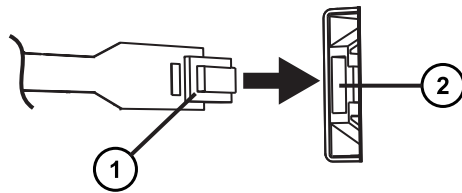

- ① Leak sensor connector
- ② Leak sensor port on front of device

11. Power-on the sample manager.
12. In the console, select the sample manager, and then click **Control > Reset SM** to reset the sample manager.
13. In the console, enable the leak sensor to activate its leak-detection capability.

2.38 Diagnostic tests

You can select these diagnostic tests from the sample manager's Maintain menu:

- Needle-seal readiness test, which confirms that there is a rise in pressure when flow is directed through the needle, the needle seal, and the static return tubing. It indirectly confirms that there is no drop in system pressure when it registers a positive rise in pressure.
- Sample syringe leak test, which verifies that the sample syringe, metering syringe valve, sample transducer, and inject valve are free of leaks. This test also verifies that the sample syringe is properly primed and that no bubbles are present.

The Maintain menu also lists these functions:

- Characterizing the needle seal, which determines the seal location.
- Replace components, which enables you to replace the sample syringe, needle, and needle seal.
- Calibrating the needle Z axis, which calibrates the vertical position of the needle.
- Disabling motors, which you do before manually moving the sample tray and R-carriage.
- Parking the sample needle and injection valve, which you do before storing the system or replacing a needle or valve.

See also:

- *Quaternary Solvent Manager Overview and Maintenance Guide* or *ACQUITY UPLC Binary Solvent Manager Operator's Overview and Maintenance Information* for information on the solvent manager's leak test.
- The console online Help for additional information about running diagnostic tests.

3 Maintenance

Perform the procedures in this section when you discover a problem with a sample manager component or during routine maintenance. For information about isolating problems in the sample manager, consult the console online Help.

3.1 Contacting Waters Technical Service

If you are located in the USA or Canada, report malfunctions or other problems to Waters Technical Service (800-252-4752). From elsewhere, phone the Waters corporate headquarters in Milford, Massachusetts (USA) or contact your local Waters subsidiary. The Waters website includes phone numbers and email addresses for Waters locations worldwide. Visit www.waters.com.

When you contact Waters, be prepared to provide the following information:

- Error message (if any)
- Nature of the symptom
- Serial number of the system module and its firmware version, if applicable
- Flow rate
- Operating pressure
- Solvent or solvents
- Detector settings (sensitivity and wavelength)
- Type and serial number of column or columns
- Sample type and diluent
- Data software version and serial number
- System workstation model and operating system version

For an explanation about how to report shipping damages and submit claims, see the document *Waters Licenses, Warranties, and Support Services* on the Waters website (www.waters.com).

For troubleshooting information, visit support.waters.com.

3.2 Viewing module information

Each system module bears a serial number that facilitates service and support. Serial numbers also provide a way to create single log entries for each module so that you can review the usage history of a particular unit.

Be prepared to provide the serial numbers of the modules in your system when you contact Waters customer support.

To view module information:

1. In the console, select a module from the system tree.
2. Click **Configure > View module information**.
The Module Information dialog box displays this information:
 - Serial number
 - Firmware version
 - Firmware checksum
 - Component software version

Alternatives:

- In the main window, point to the visual representation of the system module that you want information about.
- Obtain the serial number from the printed labels on the module's rear panel or inside the module door.

3.3 Recommended maintenance schedule

Perform the following routine maintenance on the module to ensure reliable operation and accurate results. When using the system throughout the day (and on nights and weekends), or when using aggressive solvents such as buffers, perform these maintenance tasks more frequently.

3.3.1 Recommended maintenance schedule for the sample manager

| Maintenance procedure | Frequency |
|--|--|
| Replace the leak sensors | As necessary |
| Replace the seal | During scheduled routine maintenance or as necessary |
| Replace the sample needle and needle guide | During scheduled routine maintenance or as necessary |

| Maintenance procedure | Frequency |
|---|--|
| Replace the sample syringe | During scheduled routine maintenance or as necessary |
| Clean the injection port | Weekly or monthly, according to system usage |
| Replace the injection valve cartridge | During scheduled routine maintenance or as necessary |
| Clean the module's exterior using a soft, lint-free cloth, or paper dampened with water | As necessary |

3.4 Spare parts

To ensure that your system operates as designed, use only Waters Quality Parts. Visit www.waters.com/wqp for information about Waters Quality Parts, including how to order them.

3.5 Safety and handling



Warning: Observe Good Laboratory Practice (GLP) at all times, particularly when working with hazardous materials. Consult the Material Safety Data Sheets regarding the solvents you use. Additionally, consult the safety representative for your organization regarding its protocols for handling such materials.



Warning: To avoid electric shock, do not remove protective panels from the device. The components within are not user-serviceable.



Notice: To avoid damaging electrical components and circuitry, do not disconnect an electrical assembly while electrical power is applied to a module. To completely interrupt power, set the on/off switch to the "off" position, and then disconnect the power cord from the ac source. Wait 10 seconds before disconnecting an assembly.

3.6 Configuring maintenance warnings

Maintenance counters, if available for a particular component, provide information about real-time usage that can help you determine when to schedule routine maintenance for specific components. You can specify usage thresholds and maintenance warnings that alert you when a component reaches a specified threshold. Thus you can minimize unexpected failures and unscheduled downtime during important work. For information explaining how to specify maintenance warnings, consult the Waters console Help.

3.7 Replacing the leak sensor

The sample manager is fitted with two leak sensors, bottom and top, referred to as the lower and upper leak sensors. The procedures for replacing the leak sensors are identical.



Warning: Observe Good Laboratory Practice (GLP) at all times, particularly when working with hazardous materials. Consult the Material Safety Data Sheets regarding the solvents you use. Additionally, consult the safety representative for your organization regarding its protocols for handling such materials.



Warning: To avoid personal contamination with biologically hazardous materials, wear clean, chemical-resistant, powder-free gloves when performing this procedure.



Warning: To avoid eye injury, use eye protection when performing this procedure.

Required tools and materials

- Chemical-resistant, powder-free gloves
- Protective eyewear
- Leak sensor

To replace the leak sensor:



Notice: To avoid damaging electrical components and circuitry, do not disconnect an electrical assembly while electrical power is applied to a module. To completely interrupt power, set the on/off switch to the "off" position, and then disconnect the power cord from the ac source. Wait 10 seconds before disconnecting an assembly.

1. Power-off the sample manager.
2. Open the fluidics compartment door.
3. Press down on the tab to detach the leak sensor connector from the front of the device.

Figure 3–1: Leak sensor connector

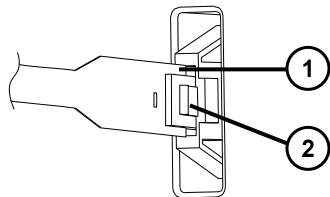

① Connector

② Tab

4. Grasp the leak sensor by its serrations and pull upward on it to remove it from its reservoir.

Figure 3–2: Leak sensor serrations

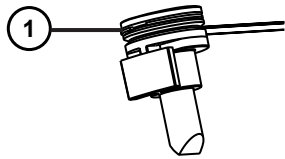

- ① Serrations

5. Unpack the new leak sensor.
6. Align the leak sensor T-bar with the slot in the side of the leak sensor reservoir and slide the leak sensor into place.

Figure 3–3: Aligning lower leak sensor T-bar with slot

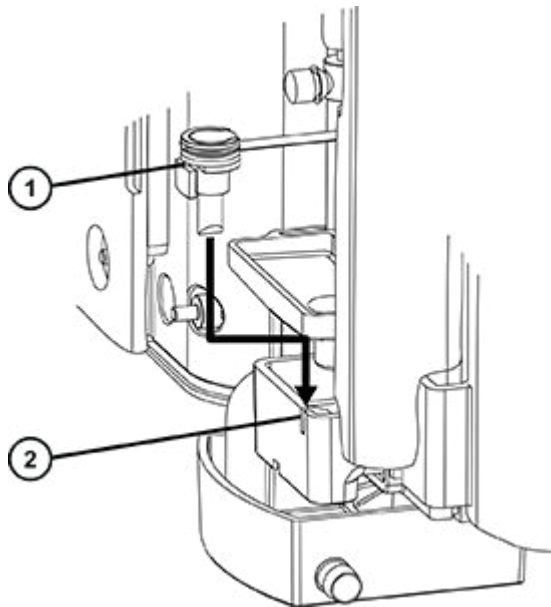

- ① T-bar
- ② Slot in leak sensor reservoir

7. Connect the leak sensor connector to the front of the sample manager.

Figure 3–4: Attaching leak sensor connector

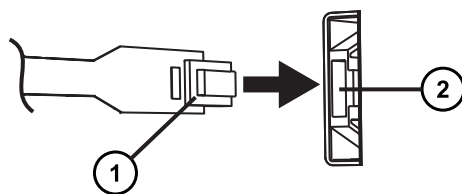

- ① Leak sensor connector
- ② Leak sensor port on front of device
8. Power-on the sample manager.
9. In the Console, select the sample manager, and then click **Control** > **Reset SM** to reset the device.
10. In the Console, enable the leak sensor to activate its leak-detection capability.

3.8 Replacing the seal



Warning: To avoid personal contamination with biologically hazardous or toxic compounds, wear clean, chemical-resistant, powder-free gloves when performing this procedure.



Warning: To avoid eye injury, use eye protection when performing this procedure.

Required tools and materials

- Chemical-resistant, powder-free gloves
- Protective eyewear
- 5/16-inch open-end wrench
- 1/4-inch open-end wrench
- 1/2-inch open-end wrench
- T10 TORX driver
- T20 TORX driver
- Seal kit

To replace the seal:

1. In the console, select the sample manager, and then click **Maintain** > **Replace components** > **Needle Seal**.
Result: A warning for the user to keep clear of the chamber appears.
2. Click **OK**.
Result: The needle carriage moves toward the back of the sample compartment.
3. Open the sample compartment door and the fluidics compartment door.

- Using the T20 TORX driver, loosen the two captive screws that secure the access panel, and then remove the panel.

Figure 3–5: Captive screws on access panel

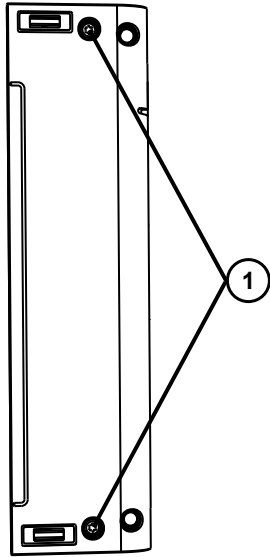

- ① Captive screws (2)

- Using the 1/4-inch open-end wrench, unscrew the seal-port tube's fitting from port 1 of the injection valve.

Figure 3–6: Location of seal-port tube on injection valve

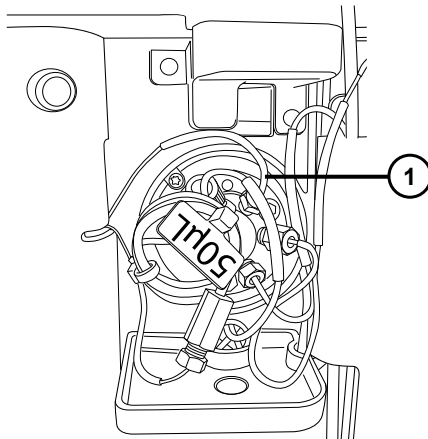

- ① Seal-port tube

- Using the T10 TORX driver, remove the screw that secures the inject/wash station assembly to the sample-compartment floor and lift the assembly upward, out of its mounting hole.

Figure 3–7: Inject/wash station assembly

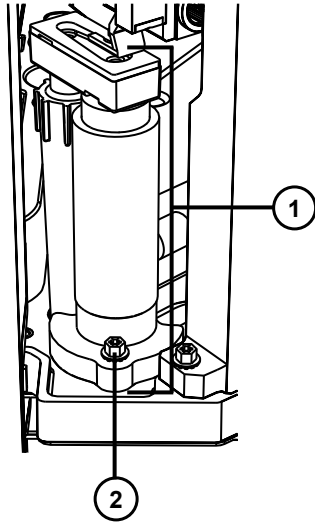

- ① Inject/wash station assembly
- ② Screw

Note: To ensure proper reinstallation of the inject/wash station assembly, note the location and routing of the wash tubing, seal-port tube, and load-cell cable before removing it.

Figure 3–8: Tubing and cable locations

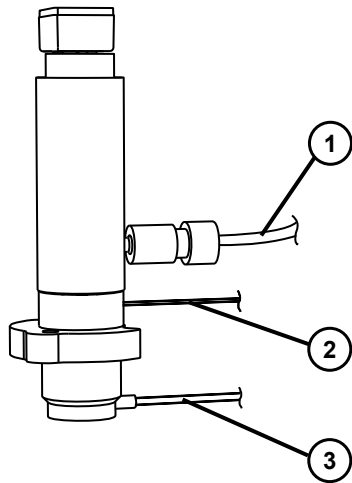

- ① Wash tubing
- ② Seal-port tube
- ③ Load-cell cable

7. Remove the wash tubing from the clip on the inside wall of the sample compartment.

Figure 3–9: Wash tubing secured by clip on sample-compartment wall

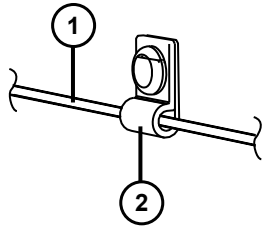

- ① Wash tubing
- ② Clip

! **Notice:** To avoid damaging the adapter fitting, ensure that you hold it while unscrewing the wash-tube fitting.

8. While holding the adapter fitting, unscrew the finger-tight wash-tube fitting from the adapter fitting.

Figure 3–10: Wash-tube and adapter fittings

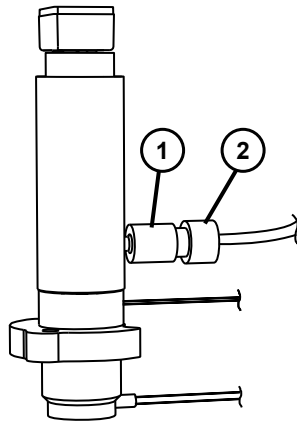

- ① Adapter fitting
- ② Wash-tube fitting

9. Unscrew the finger-tight adapter fitting from the seal assembly.
10. Slide the support sleeve from the housing and guide the seal-port tube through the slots.

Requirement: Hold the assembly in a vertical position when disassembling it. Doing so helps ensure that the spring remains in the proper position.

Figure 3–11: Sliding support sleeve out of the housing

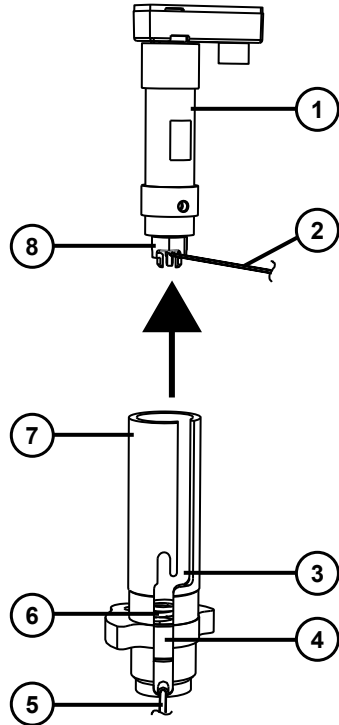

- ① Support sleeve
- ② Seal-port tube
- ③ Slot
- ④ Spring cup
- ⑤ Load-cell cable
- ⑥ Spring
- ⑦ Housing
- ⑧ Locking nut

11. Place the seal port's housing in its original location on the sample-compartment floor.

Result: Doing so helps ensure that the spring remains in the proper position.

Note: The spring can fall out of the spring cup if the seal port's housing is not placed in its original location on the sample-compartment floor.

12. Place the 1/2-inch open-end wrench on the support sleeve to hold it in place.

13. Place the 5/16-inch open-end wrench on the stainless steel locking nut.

Figure 3–12: Wrench placement locations

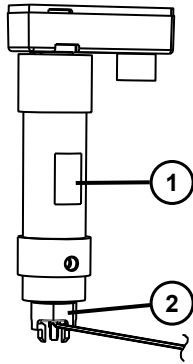

- ① Place the 1/2-inch open-end wrench here on the PEEK support sleeve.
- ② Place the 5/16-inch open-end wrench here on the stainless steel locking nut.

14. Loosen the locking nut and unscrew it from the support sleeve.

Figure 3–13: Removing locking nut from support sleeve

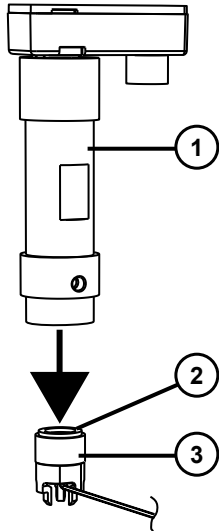

- ① Support sleeve
- ② Tube/port assembly
- ③ Locking nut

15. Remove the seal from the seal port and discard the seal.

Figure 3–14: Removing the seal from seal port

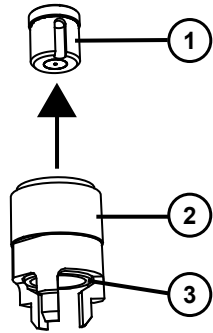

- ① Seal
- ② Locking nut
- ③ Seal port

! **Notice:** To prevent contaminating system components, wear clean, chemical-resistant, powder-free gloves, and work on a clean surface when replacing the seal.

16. Insert the new seal into the seal port. The seal is keyed, ensuring its correct installation, as shown in the following image.

Figure 3–15: Inserting new seal into seal port

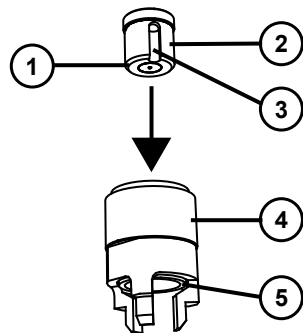

- ① Smaller-diameter end
- ② Seal
- ③ Notch
- ④ Locking nut
- ⑤ Seal port

Figure 3–16: Seal notch and pin

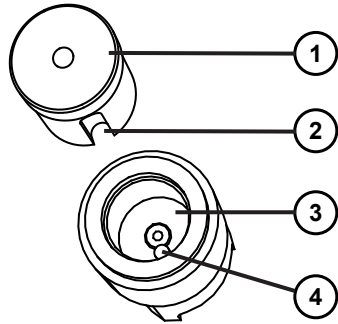

- ① Seal
- ② Notch
- ③ Seal cup
- ④ Pin

17. Finger-tighten the locking nut into the support sleeve.

Figure 3–17: Locking nut on support sleeve

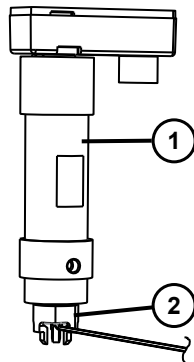

- ① Support sleeve
- ② Locking nut

18. Place the 1/2-inch open-end wrench on the support sleeve to hold the sleeve in place.



Notice: To avoid damaging the seal port tube, do not excessively twist the tube.

19. Place the 5/16-inch open-end wrench on the locking nut and tighten 1/4-turn beyond finger-tight.

Figure 3–18: Wrench placement locations

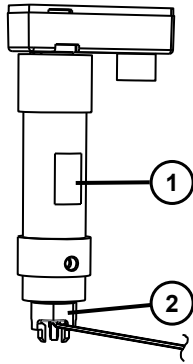

- ① Place the 1/2-inch open-end wrench here on the support sleeve.
- ② Place the 5/16-inch open-end wrench here on the locking nut.

20. Ensure that the seal-port tube is bent at 90 degrees and that it remains in line with the threaded hole in the support sleeve.

Note: To avoid interfering with the motion of the spring in the housing, the bend in the seal-port tube must not extend beyond the step in the locking nut.

Figure 3–19: Seal-port tube aligned with threaded hole

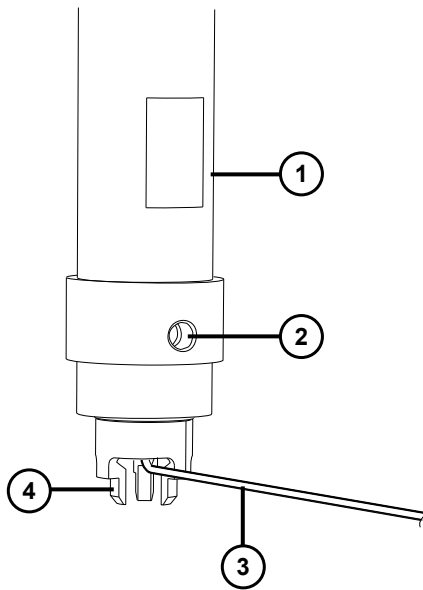

- ① Support sleeve
- ② Threaded hole

- ③ Seal-port tube
- ④ Step in locking nut

21. Slide the seal-port tube into the slot on the side of the housing.

Figure 3–20: Sliding seal-port tube into slot

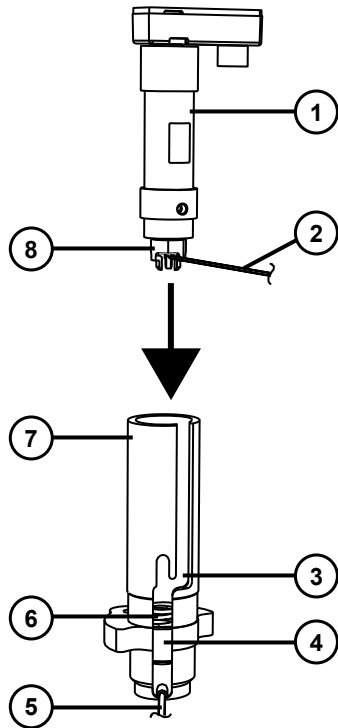

- ① Support sleeve
- ② Seal-port tube
- ③ Slot
- ④ Spring cup
- ⑤ Load-cell cable
- ⑥ Spring
- ⑦ Housing
- ⑧ Locking nut

Requirement: Ensure that the three prongs on the locking nut are seated inside the spring.

Figure 3–21: Prongs seated inside spring

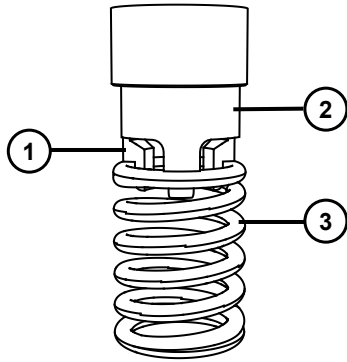

- ① Prong (3)
- ② Locking nut
- ③ Spring

22. Slide the support sleeve into the housing, ensuring that the fitting hole on the support sleeve aligns with the slot on the housing.

Figure 3–22: Support sleeve in housing

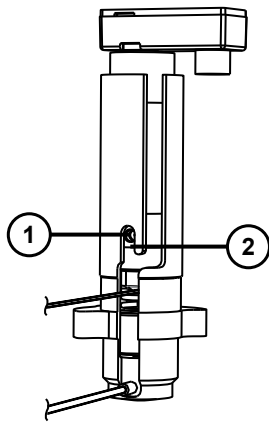

- ① Fitting hole
- ② Slot

! **Notice:** To avoid damaging the support sleeve, be careful not to cross-thread or overtighten the adapter fitting.

23. Reattach the adapter fitting to the support sleeve and tighten the fitting to the extent possible using only your fingers.

Figure 3–23: Adapter fitting in support sleeve

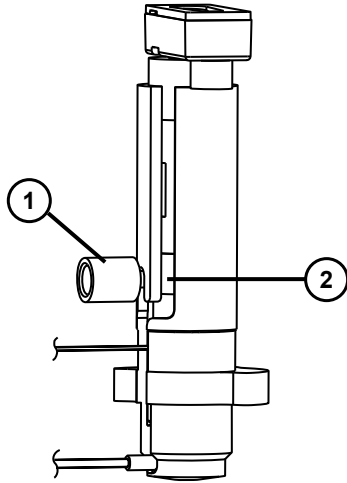

- ① Adapter fitting
- ② Support sleeve

24. Ensure that the seal-port tube is bent upward, at a 90-degree angle, and that it is approximately 2.5 cm (1.0 inch) from the housing.

Note: To avoid binding the seal-port tube, ensure that the tube does not contact either side of the inject/wash station assembly.

Figure 3–24: Seal-port tube bent upward at right angle

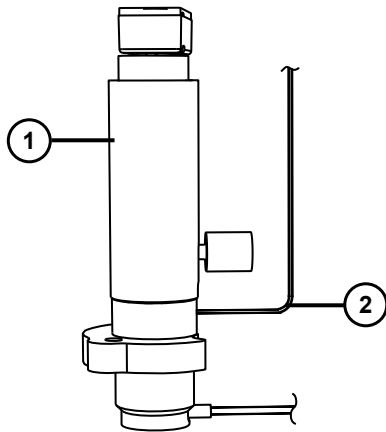

- ① Housing
- ② Seal-port tube bent upward

25. While holding the adapter fitting, screw the wash-tube fitting into the adapter fitting.

Figure 3–25: Wash-tube fitting in adapter fitting

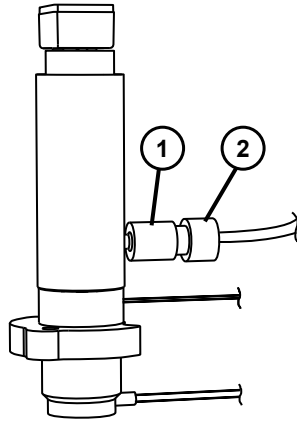

① Adapter fitting

② Wash-tube fitting

26. Place the inject/wash station assembly in its original location on the sample-compartment floor and align the screw hole with the hole in the floor, ensuring that the wash drain of the injection port is in the needle-wash basin.

Tip: There are unused holes in the sample-compartment floor.

27. Adjust the amount of tubing in the sample compartment by sliding it in and out of the foam.

Requirement: The wash tubing is secured to the wall and must not interfere with operation of the sample tray or the vertical motion of the wash port.

28. Route the wash tubing through the clip on the inside of the sample compartment.

Figure 3–26: Wash tubing secured by clip on sample-compartment wall

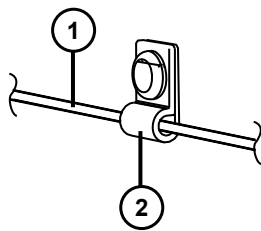

① Wash tubing

② Clip

29. Using the T10 TORX driver, tighten the screw that secures the seal assembly to the sample-compartment floor.

Figure 3–27: Inject/wash station assembly

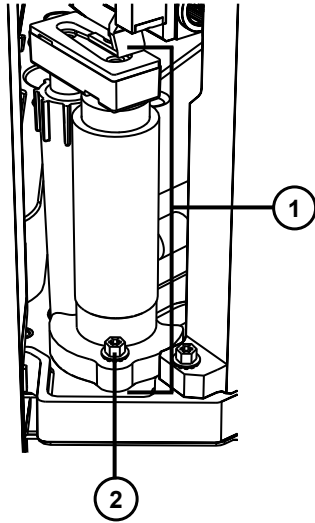

① Inject/wash station assembly

② Screw

30. Ensure that all cables are routed so that they do not interfere with the operation of the needle-carriage home sensor for the needle carriage.

Figure 3–28: Needle-carriage home sensor

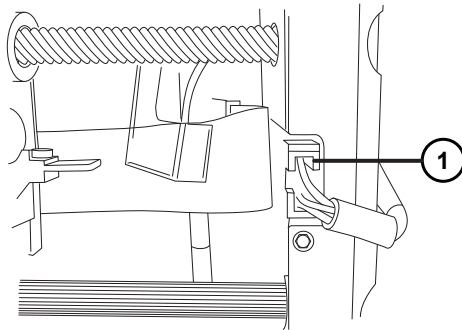

① Needle-carriage home sensor

31. Using gentle radius bends, route the seal-port tube up the right-side edge of the sample compartment, exiting behind the sample-needle tubing and to the right.

Requirement: Ensure that the cable emerges from the injection-port assembly without any tight bends.



Notice: To avoid errors in operation, ensure that the load-cell cable is routed behind the seal-port tube and the wash tubing.

Figure 3–29: Tubing and cable locations

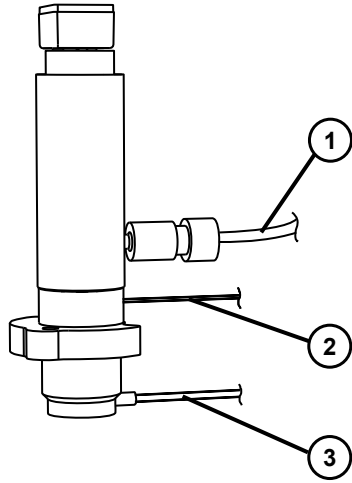

- ① Wash tubing
- ② Seal-port tube
- ③ Load-cell cable

32. Screw the seal port's fitting into port 1 of the injection valve, and then use the 1/4-inch open-end wrench to tighten the fitting 1/4-turn beyond finger-tight.

Figure 3–30: Seal-port tube location on injection valve

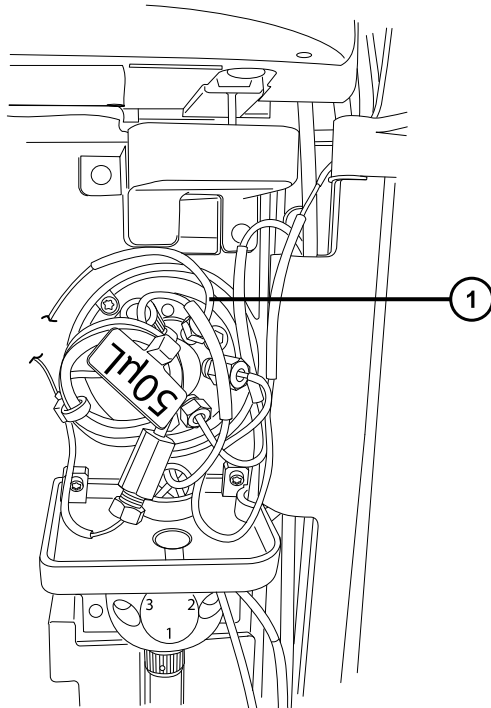

① Seal-port tube

33. Reinstall the access panel and use the T20 TORX driver to tighten the two screws that secure the panel to the front of the unit.

Requirement: Ensure that the seal-port tube and sample-needle tubing are routed through the gap in the access panel and that they do not cross each other.

Figure 3–31: Tubing routed through access-panel gap

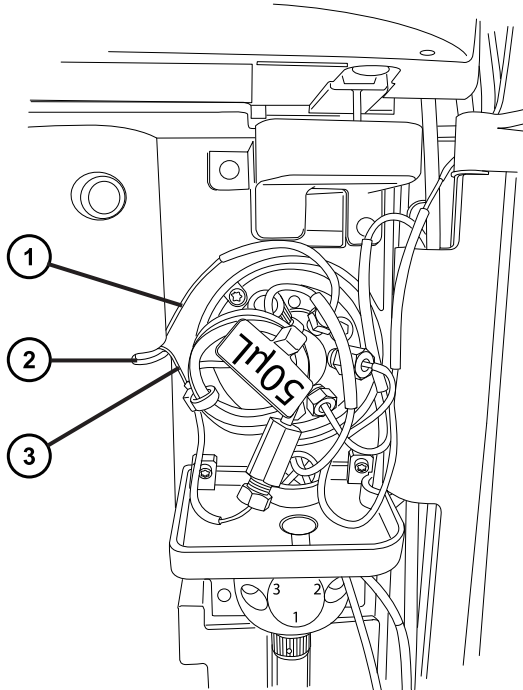

① Seal-port tube

② Access-panel gap

③ Sample-needle tubing

34. Close the sample compartment door and the fluidics compartment door.
35. In the Replace Seal dialog box, click **Reset**.
36. Characterize the needle seal (see the console online Help).
37. Perform the needle-seal readiness test (see the console online Help).

3.9 Replacing the sample needle and needle guide



Warning: To avoid personal contamination with biologically hazardous or toxic compounds, wear clean, chemical-resistant, powder-free gloves when performing this procedure.



Warning: To avoid eye injury, use eye protection when performing this procedure.

Required tools and materials

- Chemical-resistant, powder-free gloves
- Protective eyewear
- Needle-nose pliers
- 1/4-inch open-end wrench
- T6 TORX driver
- T10 TORX driver
- T20 TORX driver
- Needle assembly kit

To replace the sample needle and needle guide:

1. Power-on the sample manager.
2. Remove any sample plates from the sample chamber.
3. In the console, select the sample manager, and then click **Maintain > Replace components > Needle**.

Result: A warning for the user to keep clear of the chamber appears.

4. Click **OK**.

Result: Doing so invokes a wizard that moves the sample-needle assembly to an accessible position.

5. Open the sample compartment door and the fluidics compartment door.
6. Using a T20 TORX driver, loosen the two captive screws that secure the access panel, and then remove the panel.

Figure 3–32: Access panel captive screws

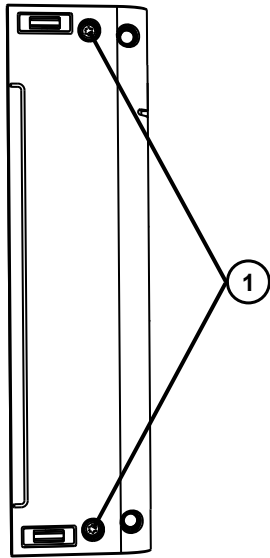

① Captive screws (2)

7. Using the 1/4-inch open-end wrench, unscrew the fitting of the needle tubing or extension loop from port 4 of the injection valve.

Figure 3–33: Injection valve

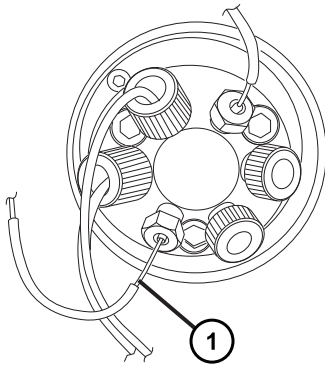

① Needle tubing (or extension loop tubing, if installed)

8. Inside the sample compartment, open the cover of the needle-tubing guide channel, located on the roof of the compartment, by inserting your finger in the finger slot and rotating the cover, as shown below.

Figure 3–34: Needle-tubing guide cover in closed position

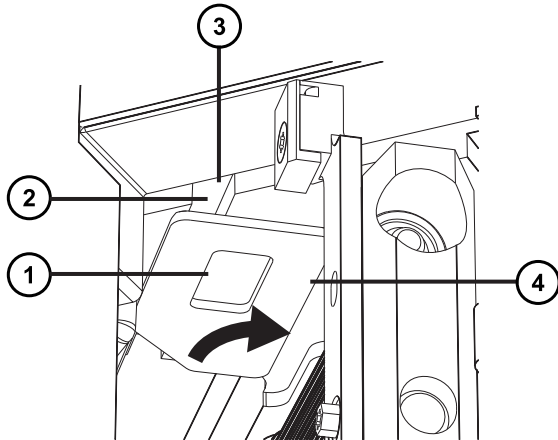

- ① Finger slot
- ② Location of needle tubing
- ③ Needle-tubing guide channel
- ④ Needle-tubing guide cover

Figure 3–35: Needle-tubing guide cover in open position

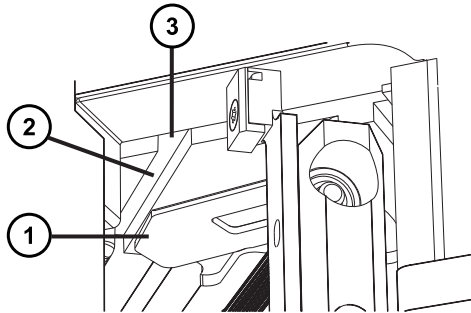

- ① Needle-tubing guide cover
- ② Location of needle tubing
- ③ Needle-tubing guide channel

9. Using a T10 TORX driver, loosen the screw on the needle-tubing clamp and remove the needle tubing from the clamp.

Figure 3–36: Needle tubing in needle-tubing clamp

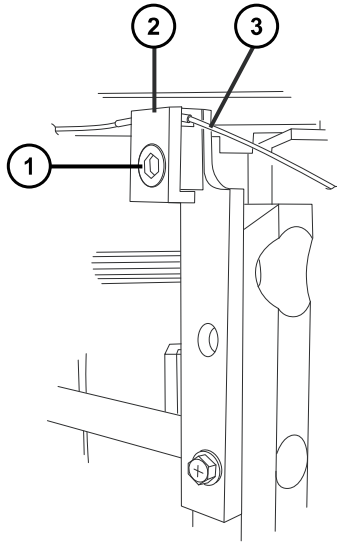

- ① Screw
- ② Needle-tubing clamp
- ③ Needle tubing

10. While holding the needle tubing, push the needle latch back to release the needle-mounting cylinder from its mounting cavity and the needle tubing from its notches.

Figure 3–37: Needle latch in closed position

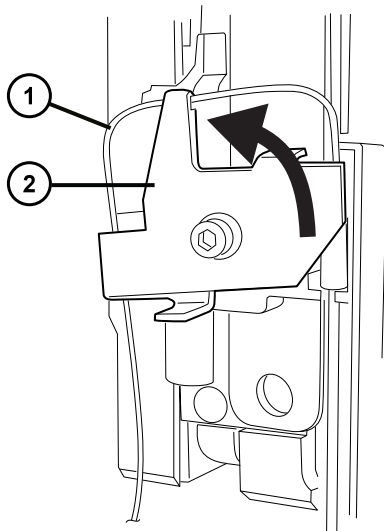

- ① Needle tubing
- ② Needle latch

Figure 3–38: Needle latch in open position

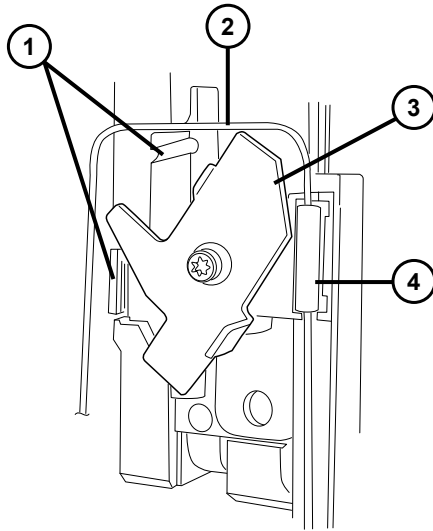

- ① Notches
- ② Needle tubing
- ③ Latch
- ④ Needle-mounting cylinder



Warning: To avoid puncture injuries, handle sample needles, syringes, fused silica lines, and borosilicate tips with extreme care.



Notice: To avoid damage to the end of the needle, do not touch or press the end of the sample needle.

11. Lift the needle tip from the needle guide, at the bottom of the needle mechanism, and remove the needle assembly from the chamber.

Figure 3–39: Needle tip in needle guide

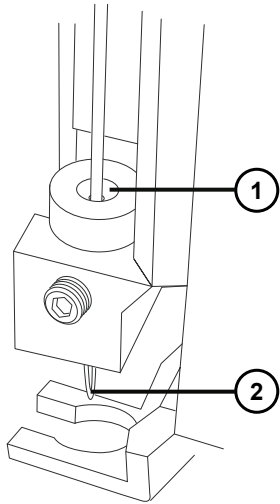

① Needle guide

② Needle tip

12. Using the T6 TORX driver, loosen the needle-guide set screw, and then use the needle-nose pliers to remove the needle guide.

Figure 3–40: Needle-guide set screw

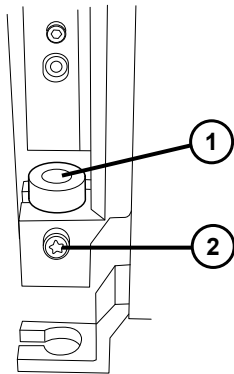

① Needle guide

② Set screw

13. Install the new needle guide conical side up and tighten the set screw.

Figure 3–41: Conical side of needle guide

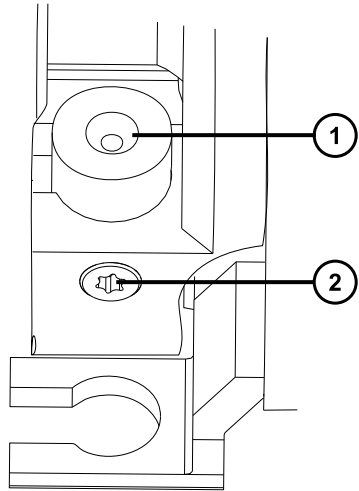

- ① Conical side of needle guide
- ② Set screw

14. Remove the protective sleeve from the needle tip.

Figure 3–42: Sample-needle assembly



- ① Fitting
- ② ID sleeve
- ③ Mounting sleeve
- ④ Needle-mounting cylinder
- ⑤ Needle tip
- ⑥ Protective sleeve



Warning: To avoid puncture injuries, handle sample needles, syringes, fused silica lines, and borosilicate tips with extreme care.



Notice: To avoid damage to the end of the needle, do not touch or press the end of the sample needle.

15. While holding the needle assembly in both hands to control its position within the sample compartment, insert the needle tip into the needle guide at the bottom of the needle mechanism, forming a loop with the tubing that extends back into the sample chamber, as shown below.

Figure 3–43: Installing needle assembly in sample compartment

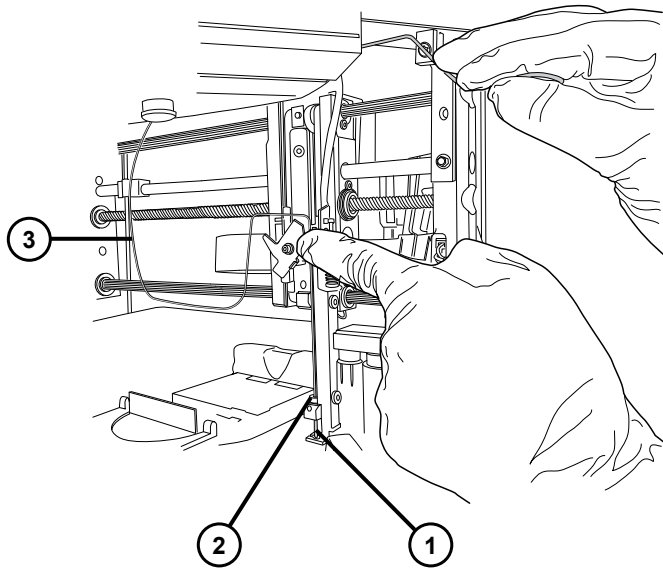

- ① Needle tip
- ② Needle guide
- ③ Needle tubing loop at the back of the sample chamber

16. Insert the needle-mounting cylinder into the mounting cavity.

Figure 3–44: Needle-mounting cylinder in mounting cavity

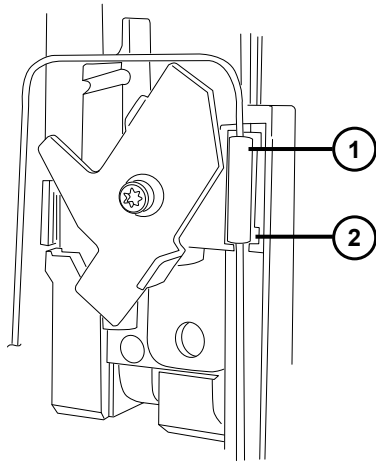

① Needle-mounting cylinder

② Mounting cavity

17. Route the needle tubing through the two notches below the Z-flag.

Figure 3–45: Notches below Z-flag

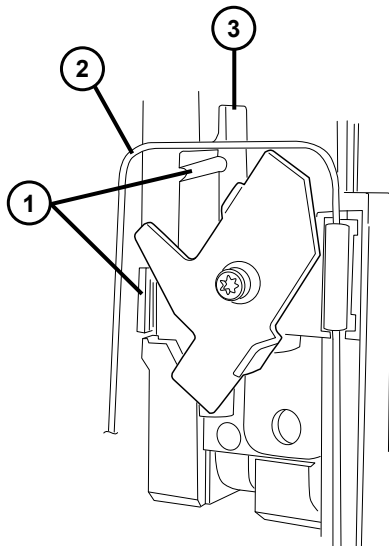

① Notches

② Needle tubing

③ Z-flag

18. Close the needle latch, as shown below, to secure the needle assembly.

Figure 3–46: Needle latch in closed position

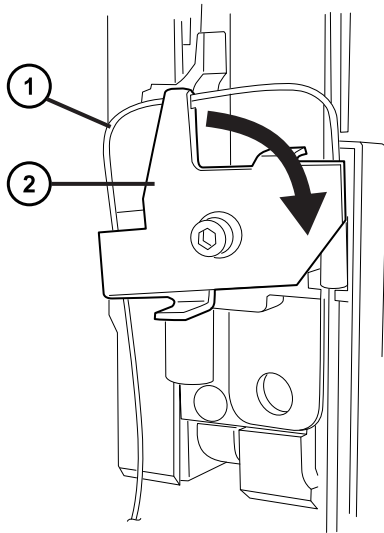

- ① Needle tubing
- ② Needle latch

19. Ensure that the needle tubing is routed to the left-hand side of the needle carriage's rails and that it is secured in the guide channel on the roof of the compartment.

Figure 3–47: Location of needle tubing in guide channel

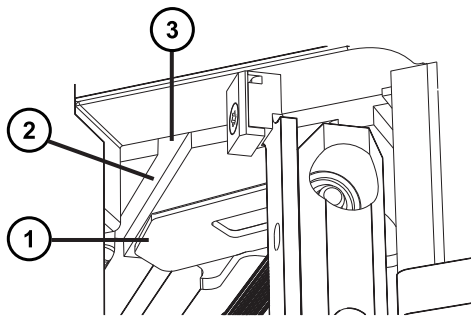

- ① Needle-tubing guide cover
- ② Location of needle tubing
- ③ Needle-tubing guide channel

20. With the needle tubing secured in the guide channel on the roof of the compartment, rotate the needle-tubing guide cover to the closed position, as shown.

Figure 3–48: Needle-tubing guide cover closed

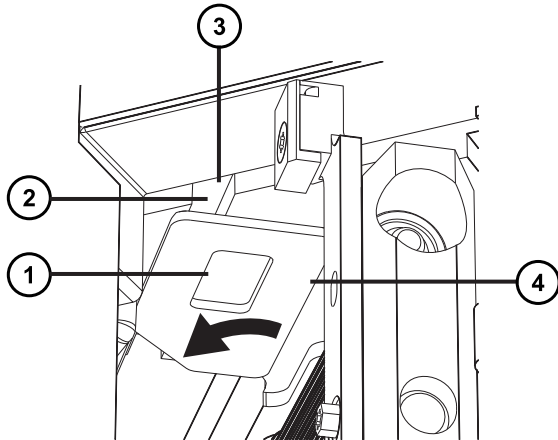

- ① Finger slot
- ② Location of needle tubing
- ③ Needle-tubing guide channel
- ④ Needle-tubing guide cover

21. Secure the mounting sleeve in the opening of the tubing clamp with the fitting oriented toward the valve.
22. Using a T10 TORX driver, tighten the screw on the needle-tubing clamp, leaving the screw loose enough to be able to move the needle in the guide.

Requirement: The needle loop must run parallel to the RZZ mechanical rods.

Figure 3–49: Sample-needle assembly installed in sample compartment

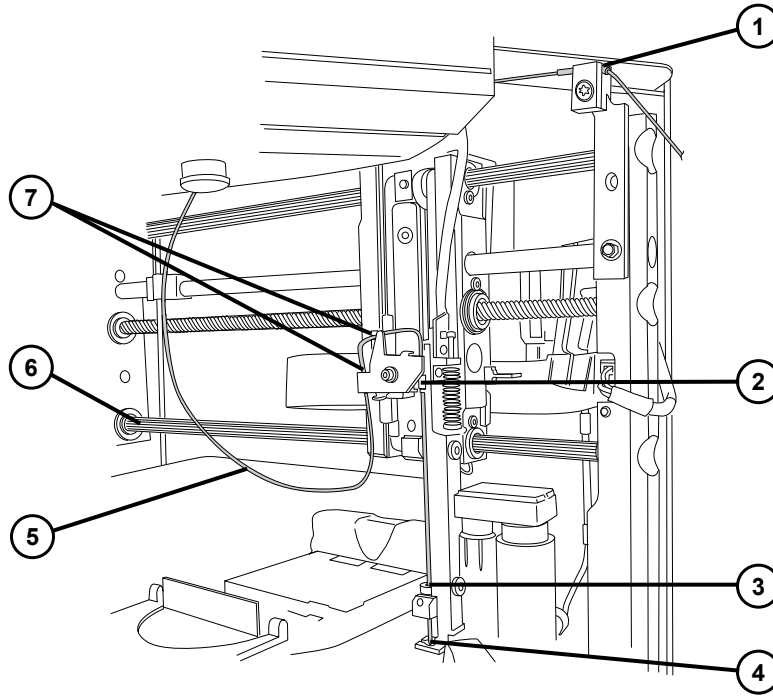

- ① Mounting sleeve in needle-tubing clamp
- ② Needle-mounting cylinder in mounting cavity
- ③ Needle tubing in needle guide
- ④ Needle tip
- ⑤ Needle tubing
- ⑥ Lower RZZ mechanical rod
- ⑦ Needle tubing in notches

23. Using the T10 TORX driver, tighten the screw on the needle-tubing clamp.

Note: You might need to slightly rotate or twist the needle to ensure that it routes straight down the channel before tightening the screw on the needle-tubing clamp.

24. At the needle-tubing clamp, bend the needle to the right, toward port 4 on the injection valve.

Tip: Use a small, rounded tool (such as a T10 TORX driver) to aid in bending the tubing.

Figure 3–50: Bending needle tubing at needle-tubing clamp

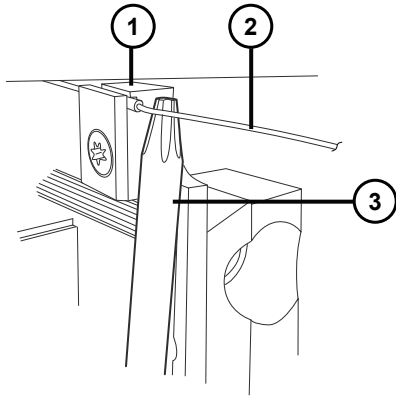

- ① Needle-tubing clamp
- ② Needle tubing
- ③ Rounded tool

25. Reinstall the access panel and use the T20 TORX driver to tighten the two screws that secure the panel to the front of the unit.

Requirement: Ensure that the seal-port tube and the sample-needle tubing are routed through the gap in the access panel.

Figure 3–51: Tubing routed through access-panel gap

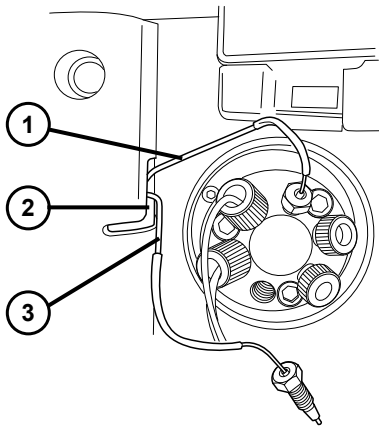

- ① Seal-port tube
- ② Access-panel gap
- ③ Sample-needle tubing

- Using a rounded tool (such as the shaft of the T20 TORX driver), make a bend and connect the needle tubing to the extension-loop port or, if the extension loop is not installed, to port 4 on the injection valve.

Figure 3–52: Needle tubing installed on injection valve

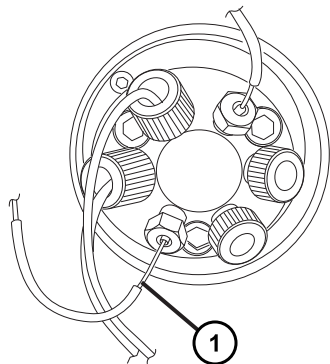

① Needle tubing

- Ensure that the needle tubing is fully inserted into port 4 on the injection valve, and then thread the fitting into the port.
- While holding the needle tubing against the bottom of the port, finger-tighten the compression screw, and then use the 1/4-inch open-end wrench to tighten an additional 3/4-turn.

Note: Failure to fully bottom the needle tubing and ferrule could cause carryover and poor chromatography.

See also: If you are using an extension loop, refer to [Installing extension loops](#) to properly connect to port 4.

- Close the sample compartment door and the fluidics compartment door.
- Calibrate the needle (see the console online Help).

Recommendation: Replace the needle seal whenever you replace the sample needle.

- Characterize the needle seal (see the console online Help).
- Perform the needle-seal readiness test (see the console online Help).
- Click **Reset**.

Result: The sample manager returns to normal operation.

- Specify the needle volume in the Volume configuration dialog box, if it changed.

3.10 Replacing the sample syringe



Warning: To avoid personal contamination with biologically hazardous or toxic compounds, wear clean, chemical-resistant, powder-free gloves when performing this procedure.



Warning: To avoid eye injury, use eye protection when performing this procedure.

Recommendation: Perform the sample-syringe leak test whenever you replace the sample syringe (see the console online Help).

Air bubbles in the sample syringe adversely affect system pressure, baseline, volume, and peak area.



Notice: To avoid breaking the sample syringe, do not attempt to remove air bubbles from the syringe by tapping on it.

Replace the sample syringe when any of these conditions arise:

- The tip of the syringe plunger becomes worn or discolored
- You want to change to the other syringe because of its size
- The syringe leaks or causes air bubbles to form

Required tools and materials

- Chemical-resistant, powder-free gloves
- Protective eyewear
- Degassed, weak-wash solvent
- Replacement sample syringe



Warning: To avoid a pinch injury or puncture wound, ensure that no injection is in progress or pending before you perform this procedure.

To replace the sample syringe:

1. In the console, select the sample manager, and then click **Maintain > Replace components > Sample Syringe**.

Result: A warning for the user to keep clear of the chamber appears.

2. Click **OK**.

Result: The syringe moves to the "down" position.

3. Open the fluidics compartment door.



Warning: To avoid solvent spills, move the solvent bottles to a location below the sample manager.

4. Move the solvent bottles to a location below the sample manager.
5. Remove the knurled screw that holds the plunger of the syringe to its mounting post.

Figure 3–53: Sample syringe components

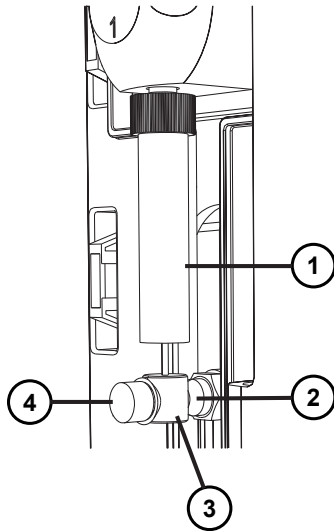

- ① Syringe barrel
- ② Mounting post
- ③ Plunger
- ④ Knurled screw



Notice: To avoid breaking the syringe, do not grasp it by its glass barrel. Always grasp the syringe by its knurled collar.

6. Unscrew the syringe, turning it counterclockwise until it separates from the sample-syringe valve.
7. Depress the syringe barrel to provide clearance for the sample-syringe valve and remove the syringe.

Figure 3–54: Removing sample syringe

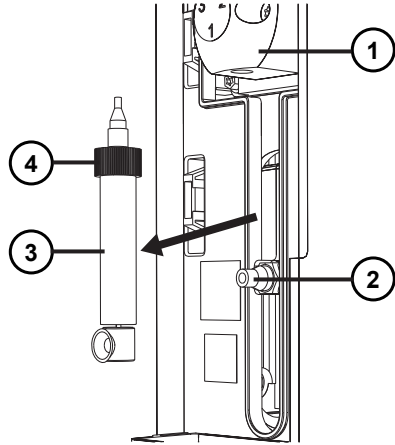

- ① Sample-syringe valve
- ② Mounting post
- ③ Syringe barrel
- ④ Knurled collar

8. Unpack the replacement sample syringe.
9. By hand, partially fill the new syringe with purge solvent to help remove air bubbles.
Requirement: Ensure that you remove all air bubbles from the syringe.
10. Depress the syringe plunger so that the syringe is completely empty.
11. Screw the new syringe into the sample-syringe valve until it is finger-tight.
12. Install and finger-tighten the knurled screw that holds the syringe plunger to the syringe mounting post.
13. Close the fluidics compartment door.
14. In the Replace Sample Syringe window, click **Reset**.
15. Run the **Prime Sample Syringe Only** function until no air bubbles remain in the syringe.

3.11 Cleaning the injection port

The surfaces of the injection port can become coated with salt or buffer buildup, especially in systems used in biopharmaceutical applications. The buildup can interfere with the motion of the injection port. To ensure consistent injection performance, clean the injection port weekly or monthly, as necessary. The frequency of cleaning varies according to the frequency of system usage and the solvent composition.



Warning: To avoid personal contamination with biologically hazardous or toxic compounds, wear clean, chemical-resistant, powder-free gloves when performing this procedure.



Warning: To avoid eye injury, use eye protection when performing this procedure.

Required tools and materials

- Chemical-resistant, powder-free gloves
- Protective eyewear
- LC/MS-grade water
- Nonabrasive, lint-free wipes
- Spray bottle
- T20 TORX driver

To clean the injection port:

1. Stop the solvent flow.
2. Open the sample compartment and fluidics compartment doors.
3. Remove any sample plates from the sample chamber.
4. In the console, select the sample manager, and then click **Maintain > Replace components > Needle Seal**.

Result: Doing so moves the needle carriage toward the back of the sample compartment, improving access to the injection port.

5. Using the T20 TORX driver, loosen the two captive screws that secure the access panel, and then remove the panel.

Figure 3–55: Access panel captive screws

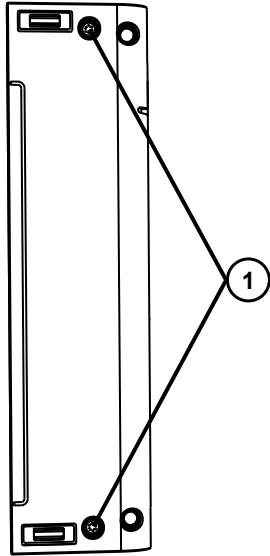

① Captive screws (2)

6. Dampen a nonabrasive, lint-free wipe with LC/MS-grade water and use it to clean the areas of the injection port shaded in the image below.

Figure 3–56: Injection port areas to clean

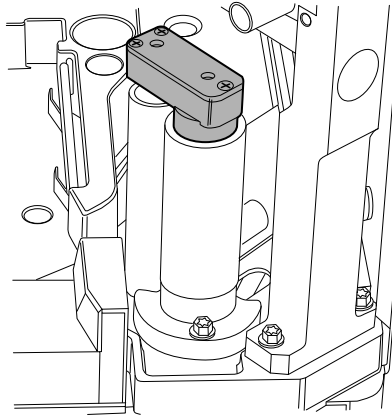

7. In the console, select the sample manager, and then click **Maintain > Replace components > Needle**.
Result: Doing so invokes a wizard that moves the sample-needle assembly to an accessible position.
8. Place a nonabrasive, lint-free wipe underneath the needle carriage.
9. Spray the needle tip and needle guide with LC/MS-grade water to wash off any deposits.

Figure 3–57: Needle tip in needle guide

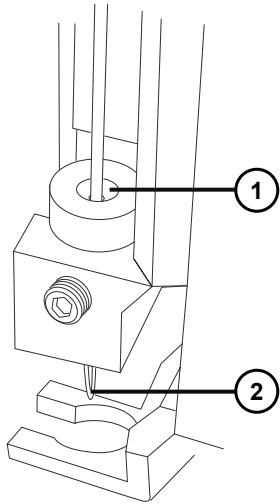

① Needle guide

② Needle tip

10. Allow the water and deposits to drip off the needle, and then carefully remove the wipe from beneath the needle.
11. Reinstall the access panel and use the T20 TORX driver to tighten the two screws that secure the panel to the front of the unit.

Requirement: Ensure that the seal-port tube and sample-needle tubing are routed through the gap in the access panel.

Figure 3–58: Tubing routed through access panel gap

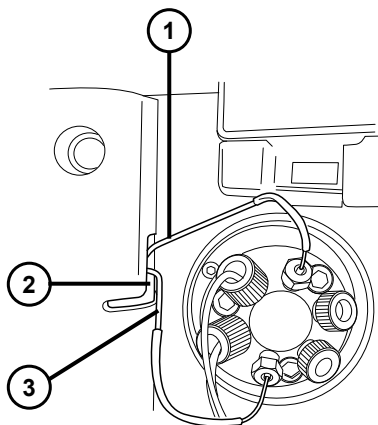

- ① Seal-port tube
 - ② Access-panel gap
 - ③ Sample-needle tubing
12. Close the sample compartment and fluidics compartment doors.
 13. In the console, select the sample manager, and then click **Control > Reset SM** to reset the sample manager.

3.12 Replacing the injection-valve cartridge



Warning: To avoid personal contamination with biologically hazardous or toxic compounds, wear clean, chemical-resistant, powder-free gloves when performing this procedure.



Warning: To avoid eye injury, use eye protection when performing this procedure.

Requirement: When you replace the injection valve, you must also replace the sample loop.



Requirement: Wear clean, chemical-resistant, powder-free gloves when performing this procedure.



Requirement: Use eye protection when performing this procedure.

Required tools and materials

- Chemical-resistant, powder-free gloves
- Protective eyewear
- 1/4-inch open-end wrench
- 2-mm hex wrench
- Injection-valve cartridge

To replace the injection-valve cartridge:

1. In the console, select the sample manager, and then click **Maintain > Park needle and injection valve > Yes**.

Result: Doing so moves the needle carriage toward the back of the sample compartment.

! **Notice:** To avoid damaging electrical components and circuitry, do not disconnect an electrical assembly while electrical power is applied to a module. To completely interrupt power, set the on/off switch to the "off" position, and then disconnect the power cord from the ac source. Wait 10 seconds before disconnecting an assembly.

2. Power-off the sample manager.
3. Open the fluidics compartment door.
4. Remove the finger-tight fittings and plugs from the injection-valve cartridge.
5. Use the 1/4-inch open-end wrench to remove the remaining fittings from the injection-valve cartridge.

Figure 3–59: Injection-valve cartridge

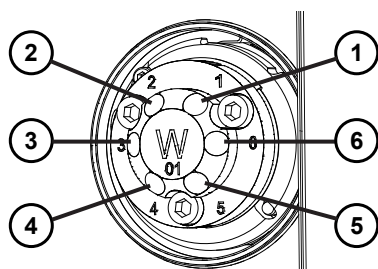

- 1 From injection port
 - 2 To waste
 - 3 Sample syringe
 - 4 Needle
 - 5 From solvent manager
 - 6 To column
6. Use the 2-mm hex wrench to remove the hex screw at the 10 o'clock position on the injection-valve cartridge.

Figure 3–60: Hex screw on injection-valve cartridge

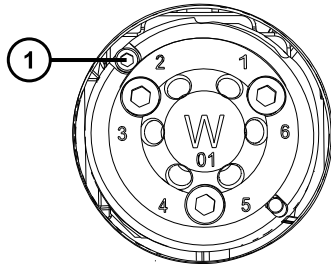

① Hex screw

7. Remove the injection-valve cartridge from the injection-valve cartridge chamber by pulling the cartridge straight forward.
8. Unpack the replacement for the injection-valve cartridge.
9. Ensure that the groove in the cartridge housing aligns with the groove on the drive clamp.

Tip: If the grooves do not align, turn the drive clamp until they do.

Note: Avoid scratching the drive clamp or body.

Figure 3–61: Correct injection-valve cartridge and drive clamp groove alignment

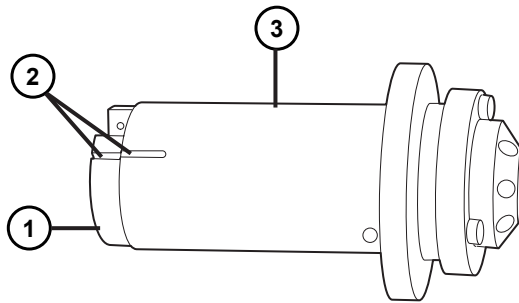

① Drive clamp

② Aligned grooves

③ Injection-valve cartridge housing

10. Insert the new injection-valve cartridge into the injection-valve cartridge chamber.

Requirements:

- Orient the new cartridge exactly as the old one was oriented.
- The injection-valve cartridge must slide fully into the injection-valve cartridge chamber. If it does not, report the problem to Waters Technical Service.

11. Insert the 2-mm hex screw at the 10 o'clock position on the injection-valve cartridge.

Tip: Use the 2-mm hex wrench to tighten it.

12. Use the 1/4-inch open-end wrench to reattach the fittings associated with the tubing for the sample needle and the seal-port tube, and tighten them as much as 1/6-turn beyond finger-tight for existing fittings, or 3/4-turn beyond finger-tight, for new fittings.
13. Reattach all finger-tight fittings and plugs, ensuring that the tubes bottom in their fitting holes.
14. Close the fluidics compartment door.
15. Power-on the sample manager.

3.13 Cleaning the exterior of the equipment



Warning: To avoid electric shock,

- ensure that the electrical power to the equipment is interrupted;
- when cleaning the surface of the equipment, apply water to a cloth, and then wipe the instrument or device. Do not spray or otherwise apply water directly onto any equipment surface.



Warning: To avoid personal injury, use eye and hand protection during the cleaning process.

Required tools and materials

- Chemical-resistant, powder-free gloves
- Protective eyewear

To clean the exterior of the equipment:

Clean surfaces of the equipment using only a clean, soft, lint-free paper towel or clean cloth dampened with water.

A Safety advisories

Waters products display safety symbols that identify hazards associated with the product's operation and maintenance. The symbols also appear in product manuals with statements that describe the hazards and advise how to avoid them. This appendix presents all safety symbols and statements that apply to Waters' product offerings. The symbols and statements can apply to a specific product, or apply to other products within the same system.

A.1 Warning symbols

Warning symbols alert you to the risk of death, injury, or seriously adverse physiological reactions associated with the misuse of an instrument or device. Heed all warnings when you install, repair, or operate any Waters instrument or device. Waters accepts no liability in cases of injury or property damage resulting from the failure of individuals to comply with any safety precaution when installing, repairing, or operating any of its instruments or devices.

The following symbols warn of risks that can arise when you operate or maintain a Waters instrument or device or component of an instrument or device. When one of these symbols appears in a manual's narrative sections or procedures, an accompanying statement identifies the applicable risk and explains how to avoid it.



Warning: (General risk of danger. When this symbol appears on an instrument, consult the instrument's user documentation for important safety-related information before you use the instrument.)



Warning: (Risk of burn injury from contacting hot surfaces.)



Warning: (Risk of electric shock.)



Warning: (Risk of fire.)



Warning: (Risk of sharp-point puncture injury.)



Warning: (Risk of hand crush injury.)



Warning: (Risk of injury caused by moving machinery.)



Warning: (Risk of exposure to ultraviolet radiation.)



Warning: (Risk of contacting corrosive substances.)



Warning: (Risk of exposure to a toxic substance.)



Warning: (Risk of personal exposure to laser radiation.)



Warning: (Risk of exposure to biological agents that can pose a serious health threat.)



Warning: (Risk of tipping.)



Warning: (Risk of explosion.)



Warning: (Risk of high-pressure gas release.)

A.1.1 Specific warnings

A.1.1.1 Burst warning

This warning applies to Waters instruments and devices fitted with nonmetallic tubing.



Warning: To avoid injury from bursting, nonmetallic tubing, heed these precautions when working in the vicinity of such tubing when it is pressurized:

- Wear eye protection.
- Extinguish all nearby flames.
- Do not use tubing that is, or has been, stressed or kinked.
- Do not expose nonmetallic tubing to compounds with which it is chemically incompatible: tetrahydrofuran, nitric acid, and sulfuric acid, for example.
- Be aware that some compounds, like methylene chloride and dimethyl sulfoxide, can cause nonmetallic tubing to swell, significantly reducing the pressure at which the tubing can rupture.

A.1.1.2 Biohazard warning

The following warning applies to Waters instruments and devices that can process biologically hazardous materials. Biologically hazardous materials are substances that contain biological agents capable of producing harmful effects in humans.



Warning: To avoid infection from blood-borne pathogens, inactivated microorganisms, and other biological materials, assume that all biological fluids that you handle are infectious.

Specific precautions appear in the latest edition of the US National Institutes of Health (NIH) publication *Biosafety in Microbiological and Biomedical Laboratories* (BMBL).



Warning: Observe Good Laboratory Practice (GLP) at all times, particularly when working with hazardous materials. Consult the Material Safety Data Sheets regarding the solvents you use. Additionally, consult the safety representative for your organization regarding its protocols for handling such materials.

A.1.1.3 Biohazard and chemical hazard warning

This warning applies to Waters instruments and devices that can process biohazards, corrosive materials, or toxic materials.



Warning: To avoid personal contamination with biologically hazardous, toxic, or corrosive materials, you must understand the hazards associated with their handling.

Guidelines prescribing the proper use and handling of such materials appear in the latest edition of the National Research Council's publication, *Prudent Practices in the Laboratory: Handling and Management of Chemical Hazards*.

Observe Good Laboratory Practice (GLP) at all times, particularly when working with hazardous materials, and consult the safety representative for your organization regarding its protocols for handling such materials.

A.2 Notices

Notice advisories appear where an instrument, device, or component can be subject to use or misuse that can damage it or compromise a sample's integrity. The exclamation point symbol and its associated statement alert you to such risk.



Notice: To avoid damaging the case of the instrument or device, do not clean it with abrasives or solvents.

A.3 Bottles Prohibited symbol

The Bottles Prohibited symbol alerts you to the risk of equipment damage caused by solvent spills.



Prohibited: To avoid equipment damage caused by spilled solvent, do not place reservoir bottles directly atop an instrument or device or on its front ledge. Instead, place the bottles in the bottle tray, which serves as secondary containment in the event of spills.

A.4 Required protection

The Use Eye Protection and Wear Protective Gloves symbols alert you to the requirement for personal protective equipment. Select appropriate protective equipment according to your organization's standard operating procedures.



Requirement: Use eye protection when performing this procedure.



Requirement: Wear clean, chemical-resistant, powder-free gloves when performing this procedure.

A.5 Warnings that apply to all Waters instruments and devices

When operating this device, follow standard quality-control procedures and the equipment guidelines in this section.



Warning: Changes or modifications to this unit not expressly approved by the party responsible for compliance could void the user's authority to operate the equipment.



Avertissement : Toute modification sur cette unité n'ayant pas été expressément approuvée par l'autorité responsable de la conformité à la réglementation peut annuler le droit de l'utilisateur à exploiter l'équipement.



Warnung: Jedwede Änderungen oder Modifikationen an dem Gerät ohne die ausdrückliche Genehmigung der für die ordnungsgemäße Funktionstüchtigkeit verantwortlichen Personen kann zum Entzug der Bedienungsbefugnis des Systems führen.



Avvertenza: qualsiasi modifica o alterazione apportata a questa unità e non espressamente autorizzata dai responsabili per la conformità fa decadere il diritto all'utilizzo dell'apparecchiatura da parte dell'utente.



Advertencia: cualquier cambio o modificación efectuado en esta unidad que no haya sido expresamente aprobado por la parte responsable del cumplimiento puede anular la autorización del usuario para utilizar el equipo.



警告: 未经有关法规认证部门明确允许对本设备进行的改变或改装,可能会使使用者丧失操作该设备的合法性。



警告: 未經有關法規認證部門允許對本設備進行的改變或修改,可能會使使用者喪失操作該設備的權利。



경고: 규정 준수를 책임지는 당사자의 명백한 승인 없이 이 장치를 개조 또는 변경할 경우, 이 장치를 운용할 수 있는 사용자 권한의 효력을 상실할 수 있습니다.



警告: 規制機関から明確な承認を受けずに本装置の変更や改造を行うと、本装置のユーザーとしての承認が無効になる可能性があります。



Warning: Use caution when working with any polymer tubing under pressure:

- Always wear eye protection when near pressurized polymer tubing.
- Extinguish all nearby flames.
- Do not use tubing that has been severely stressed or kinked.
- Do not use nonmetallic tubing with tetrahydrofuran (THF) or concentrated nitric or sulfuric acids.
- Be aware that methylene chloride and dimethyl sulfoxide cause nonmetallic tubing to swell, which greatly reduces the rupture pressure of the tubing.



Avertissement : Manipulez les tubes en polymère sous pression avec précaution:

- Portez systématiquement des lunettes de protection lorsque vous vous trouvez à proximité de tubes en polymère pressurisés.
- Eteignez toute flamme se trouvant à proximité de l'instrument.
- Evitez d'utiliser des tubes sévèrement déformés ou endommagés.
- Evitez d'utiliser des tubes non métalliques avec du tétrahydrofurane (THF) ou de l'acide sulfurique ou nitrique concentré.
- Sachez que le chlorure de méthylène et le diméthylesulfoxyde entraînent le gonflement des tuyaux non métalliques, ce qui réduit considérablement leur pression de rupture.



Warnung: Bei der Arbeit mit Polymerschläuchen unter Druck ist besondere Vorsicht angebracht:

- In der Nähe von unter Druck stehenden Polymerschläuchen stets Schutzbrille tragen.
- Alle offenen Flammen in der Nähe löschen.
- Keine Schläuche verwenden, die stark geknickt oder überbeansprucht sind.
- Nichtmetallische Schläuche nicht für Tetrahydrofuran (THF) oder konzentrierte Salpeter- oder Schwefelsäure verwenden.
- Durch Methylenchlorid und Dimethylsulfoxid können nichtmetallische Schläuche quellen; dadurch wird der Berstdruck des Schlauches erheblich reduziert.



Avvertenza: fare attenzione quando si utilizzano tubi in materiale polimerico sotto pressione:

- Indossare sempre occhiali da lavoro protettivi nei pressi di tubi di polimero pressurizzati.
- Spegnerle tutte le fiamme vive nell'ambiente circostante.
- Non utilizzare tubi eccessivamente logorati o piegati.
- Non utilizzare tubi non metallici con tetraidrofurano (THF) o acido solforico o nitrico concentrati.
- Tenere presente che il cloruro di metilene e il dimetilsolfossido provocano rigonfiamenti nei tubi non metallici, riducendo notevolmente la pressione di rottura dei tubi stessi.



Advertencia: se recomienda precaución cuando se trabaje con tubos de polímero sometidos a presión:

- El usuario deberá protegerse siempre los ojos cuando trabaje cerca de tubos de polímero sometidos a presión.
- Si hubiera alguna llama las proximidades.
- No se debe trabajar con tubos que se hayan doblado o sometido a altas presiones.
- Es necesario utilizar tubos de metal cuando se trabaje con tetrahydrofuran (THF) o ácidos nítrico o sulfúrico concentrados.
- Hay que tener en cuenta que el cloruro de metileno y el sulfóxido de dimetilo dilatan los tubos no metálicos, lo que reduce la presión de ruptura de los tubos.



警告： 当有压力的情况下使用管线时，小心注意以下几点：

- 当接近有压力的聚合物管线时一定要戴防护眼镜。
- 熄灭附近所有的火焰。
- 不要使用已经被压瘪或严重弯曲的管线。
- 不要在非金属管线中使用四氢呋喃或浓硝酸或浓硫酸。
- 要了解使用二氯甲烷及二甲基亚砜会导致非金属管线膨胀，大大降低管线的耐压能力。



警告： 當在有壓力的情況下使用聚合物管線時，小心注意以下幾點。

- 當接近有壓力的聚合物管線時一定要戴防護眼鏡。
- 熄滅附近所有的火焰。
- 不要使用已經被壓癟或嚴重彎曲管線。
- 不要在非金屬管線中使用四氫呋喃或濃硝酸或濃硫酸。
- 要了解使用二氯甲烷及二甲基亞砜會導致非金屬管線膨脹，大大降低管線的耐壓能力。



경고: 가압 폴리머 튜브로 작업할 경우에는 주의하십시오.

- 가압 폴리머 튜브 근처에서는 항상 보호 안경을 착용하십시오.
- 근처의 화기를 모두 끄십시오.
- 심하게 변형되거나 꼬인 튜브는 사용하지 마십시오.
- 비금속(Nonmetallic) 튜브를 테트라히드로푸란(Tetrahydrofuran: THF) 또는 농축 질산 또는 황산과 함께 사용하지 마십시오.
- 염화 메틸렌(Methylene chloride) 및 디메틸설폭사이드(Dimethyl sulfoxide)는 비금속 튜브를 부풀려 튜브의 파열 압력을 크게 감소시킬 수 있으므로 유의하십시오.



警告: 圧力のかかったポリマーチューブを扱うときは、注意してください。

- 加圧されたポリマーチューブの付近では、必ず保護メガネを着用してください。
- 近くにある火を消してください。
- 著しく変形した、または折れ曲がったチューブは使用しないでください。
- 非金属チューブには、テトラヒドロフラン(THF)や高濃度の硝酸または硫酸などを流さないでください。
- 塩化メチレンやジメチルスルホキシドは、非金属チューブの膨張を引き起こす場合があり、その場合、チューブは極めて低い圧力で破裂します。

This warning applies to Waters instruments fitted with nonmetallic tubing. This warning applies to instruments operated with flammable solvents.



Warning: The user shall be made aware that if the equipment is used in a manner not specified by the manufacturer, the protection provided by the equipment may be impaired.



Avertissement : L'utilisateur doit être informé que si le matériel est utilisé d'une façon non spécifiée par le fabricant, la protection assurée par le matériel risque d'être défectueuses.



Warnung: Der Benutzer wird darauf aufmerksam gemacht, dass bei unsachgemäßer Verwendung des Gerätes die eingebauten Sicherheitseinrichtungen unter Umständen nicht ordnungsgemäß funktionieren.



Avvertenza: si rende noto all'utente che l'eventuale utilizzo dell'apparecchiatura secondo modalità non previste dal produttore può compromettere la protezione offerta dall'apparecchiatura.



Advertencia: el usuario deberá saber que si el equipo se utiliza de forma distinta a la especificada por el fabricante, las medidas de protección del equipo podrían ser insuficientes.



警告： 使用者必須非常清楚如果設備不是按照製造廠商指定的方式使用，那麼該設備所提供的保護將被削弱。



警告： 使用者必須非常清楚如果設備不是按照製造廠商指定的方式使用，那麼該設備所提供的保護將被削弱。



경고: 제조업체가 명시하지 않은 방식으로 장비를 사용할 경우 장비가 제공하는 보호 수단이 제대로 작동하지 않을 수 있다는 점을 사용자에게 반드시 인식시켜야 합니다.



警告: ユーザーは、製造元により指定されていない方法で機器を使用すると、機器が提供している保証が無効になる可能性があることに注意して下さい。

A.6 Warnings that address the replacement of fuses

The following warnings pertain to instruments and devices equipped with user-replaceable fuses. Information describing fuse types and ratings sometimes, but not always, appears on the instrument or device.

Finding fuse types and ratings when that information appears on the instrument or device:



Warning: To protect against fire, replace fuses with those of the type and rating printed on panels adjacent to instrument fuse covers.



Avertissement : pour éviter tout risque d'incendie, remplacez toujours les fusibles par d'autres du type et de la puissance indiqués sur le panneau à proximité du couvercle de la boîte à fusible de l'instrument.



Warnung: Zum Schutz gegen Feuer die Sicherungen nur mit Sicherungen ersetzen, deren Typ und Nennwert auf den Tafeln neben den Sicherungsabdeckungen des Geräts gedruckt sind.



Avvertenza: per garantire protezione contro gli incendi, sostituire i fusibili con altri dello stesso tipo aventi le caratteristiche indicate sui pannelli adiacenti alla copertura fusibili dello strumento.



Advertencia: Para evitar incendios, sustituir los fusibles por aquellos del tipo y características impresos en los paneles adyacentes a las cubiertas de los fusibles del instrumento.



警告： 为了避免火灾，应更换与仪器保险丝盖旁边面板上印刷的类型和规格相同的保险丝。



警告： 为了避免火灾，更换保险丝时，请使用与仪器保险丝盖旁面板上所印刷之相同类型与规格的保险丝。



경고: 화재의 위험을 막으려면 기기 퓨즈 커버에 가까운 패널에 인쇄된 것과 동일한 타입 및 정격의 제품으로 퓨즈를 교체하십시오.



警告: 火災予防のために、ヒューズ交換では機器ヒューズカバー脇のパネルに記載されているタイプおよび定格のヒューズをご使用ください。

Finding fuse types and ratings when that information does not appear on the instrument or device:



Warning: To protect against fire, replace fuses with those of the type and rating indicated in the "Replacing fuses" section of the Maintenance Procedures chapter.



Avertissement : pour éviter tout risque d'incendie, remplacez toujours les fusibles par d'autres du type et de la puissance indiqués dans la rubrique "Remplacement des fusibles" du chapitre traitant des procédures de maintenance.



Warnung: Zum Schutz gegen Feuer die Sicherungen nur mit Sicherungen ersetzen, deren Typ und Nennwert im Abschnitt "Sicherungen ersetzen" des Kapitels "Wartungsverfahren" angegeben sind.



Avvertenza: per garantire protezione contro gli incendi, sostituire i fusibili con altri dello stesso tipo aventi le caratteristiche indicate nel paragrafo "Sostituzione dei fusibili" del capitolo "Procedure di manutenzione".



Advertencia: Para evitar incendios, sustituir los fusibles por aquellos del tipo y características indicados en la sección "Sustituir fusibles".



警告： 为了避免火灾，应更换“维护步骤”一章的“更换保险丝”一节中介绍的相同类型和规格的保险丝。



警告： 為了避免火災，更換保險絲時，應使用「維護步驟」章節中「更換保險絲」所指定之相同類型與規格的保險絲。



경고: 화재의 위험을 막으려면 유지관리 절차 단원의 “퓨즈 교체” 절에 설명된 것과 동일한 타입 및 정격의 제품으로 퓨즈를 교체하십시오.



警告: 火災予防のために、ヒューズ交換ではメンテナンス項目の「ヒューズの交換」に記載されているタイプおよび定格のヒューズをご使用ください。







A.7 Electrical symbols

The following electrical symbols and their associated statements can appear in instrument manuals and on an instrument's front or rear panels.

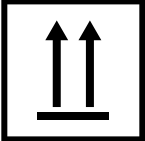
| Symbol | Description |
|--------|---|
| | Electrical power on |
| ○ | Electrical power off |
| ⏻ | Standby |
| ≡ | Direct current |
| ~ | Alternating current |
| 3~ | Alternating current (three phase) |
| ⊕ | Safety ground |
| ⏏ | Frame or chassis terminal connection |
| ⊞ | Fuse |
| ⏚ | Functional ground |
| ⊞→ | Input |
| ⊞← | Output |
| | Indicates that the device or assembly is susceptible to damage from electrostatic discharge (ESD) |

A.8 Handling symbols

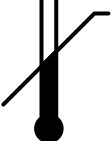
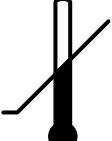
The following handling symbols and their associated statements can appear on labels affixed to the packaging in which instruments, devices, and component parts are shipped.

| Symbol | Description |
|---|----------------------------|
|  | Keep upright! |
|  | Keep dry! |
|  | Fragile! |
|  | Use no hooks! |
|  | Upper limit of temperature |
|  | Lower limit of temperature |
|  | Temperature limitation |

B Specifications

The reproducibility of the specifications presented in this document depends on the conditions in individual laboratories. Contact the Waters Technical Service organization for additional information about specifications.

B.1 SM-FTN and bioSM-FTN physical specifications

| Attribute | Specification |
|-----------|--|
| Height | 27.1 cm (10.7 in) with .64 cm (0.25 in) feet |
| Width | 34.3 cm (13.5 in) |
| Depth | 71.2 cm (28.0 in) |
| Weight | 26.1 kg (57.5 lb) |

B.2 SM-FTN and bioSM-FTN environmental specifications

| Attribute | Specification |
|----------------------------------|--------------------------|
| Acoustic noise | <65 dBA, system |
| Ambient operating temperature | 4 to 40 °C |
| Ambient operating humidity | 20 to 80%, noncondensing |
| Shipping and storage temperature | -30 to 60 °C |
| Shipping and storage humidity | 20 to 80%, noncondensing |

B.3 SM-FTN and bioSM-FTN electrical specifications

| Attribute | Specification |
|-------------------------------|---------------|
| Protection class ^a | Class I |

| Attribute | Specification |
|-----------------------------------|----------------|
| Overvoltage category ^b | II |
| Pollution degree ^c | 2 |
| Moisture protection ^d | Normal (IPX0) |
| Line voltages, nominal | Grounded AC |
| Voltage range | 100 to 240 Vac |
| Frequency | 50 to 60 Hz |
| Maximum power draw | 400 VA |

- a. **Protection Class I** – The insulating scheme used in the instrument to protect from electrical shock. Class I identifies a single level of insulation between live parts (wires) and exposed conductive parts (metal panels), in which the exposed conductive parts are connected to a grounding system. In turn, this grounding system is connected to the third pin (ground pin) on the electrical power cord plug.
- b. **Overvoltage Category II** – Pertains to instruments that receive their electrical power from a local level such as an electrical wall outlet.
- c. **Pollution Degree 2** – A measure of pollution on electrical circuits that can produce a reduction of dielectric strength or surface resistivity. Degree 2 refers only to normally nonconductive pollution. Occasionally, however, expect a temporary conductivity caused by condensation.
- d. **Moisture Protection** – Normal (IPX0) – IPX0 means that no Ingress Protection against any type of dripping or sprayed water exists. The “X” is a placeholder that identifies protection against dust, if applicable.

B.4 SM-FTN and bioSM-FTN input/output specifications

| Attribute | Specification |
|---------------------------------------|---|
| Event output relay (Inject Start Out) | Maximum current: 0.5 A Maximum input voltage: 30 Vdc Contact resistance: 0.2 ohms |
| Digital input signal (Inject Hold In) | Maximum input voltage: 30 Vdc Logic high: 3.0 Vdc Logic low: 1.9 Vdc |

B.5 SM-FTN and bioSM-FTN performance specifications

| Item | Specification |
|------------------------|---|
| Injection volume range | <ul style="list-style-type: none"> • With the standard loop fitted, 0.1 to 10.0 μL, in 0.1 μL increments. • With one of the optional extension loops fitted, as much as the volume of the extension loop (50, 100, 250, or 1000 μL). |

| Item | Specification |
|-------------------------|--|
| Accuracy (aspiration) | ±0.2 µL, measured by fluid weight removed from vial by means of 10-µL injections, averaged over 20 injections, using a 100-µL syringe. |
| Linearity | <p>>0.999 (standard needle)</p> <p>Test conditions:</p> <ul style="list-style-type: none"> • Chromatography: isocratic • Mobile phase: 10:90 acetonitrile/water • Flow rate: 0.6 mL/min • Needle volume: 1 to 70% • Sample mix: caffeine 0.03 mg/mL (0.2 to 10.0 µL, with 15 µL needle installed, no extension loop) • Column: ACQUITY UPLC BEH C₁₈, 1.7 µm, 2.1 × 50 mm • Detector: UV, 273-nm wavelength • Column temperature: 40 °C ±0.3 °C |
| Precision | <p><1% area RSD, 0.2 to 1.9 µL (0.25 to 0.50 mg/mL caffeine), <0.5% area RSD, 2.0 to 10.0 µL (0.03 mg/mL caffeine)</p> <p>Test conditions:</p> <ul style="list-style-type: none"> • Chromatography: isocratic • Replicates: 6 • Mobile phase: 10:90 acetonitrile/water • Flow rate: 0.6 mL/min • Column: ACQUITY UPLC BEH C₁₈, 1.7 µm, 2.1 × 50 mm • Detector: UV, 273-nm wavelength • Column temperature: 40 °C ±0.3 °C |
| Number of sample plates | <p>Any two of the following Waters-certified plates:</p> <ul style="list-style-type: none"> • 96 and 384 microtiter plates • 48-position, 2.00-mL vial plates • 48-position, 0.65-mL micro-centrifuge tube plates • 24-position, 1.50-mL micro-centrifuge tube plates <p>For more information, see the <i>Waters Sample Vials and Accessories Brochure</i> (720001818EN) or visit the plate selector and vial selector on the Waters website.</p> |

| Item | Specification |
|---|---|
| Maximum sample capacity | 768 in two, 384-well Waters-certified plates, or 96 in 2-mL vial holders. Four additional positions for dilution functions. For more information, see the <i>Waters Sample Vials and Accessories Brochure</i> , or visit the plate selector and vial selector on the Waters website. |
| Sample compartment temperature range | Between 4 and 40 °C, settable in increments of 0.1 °C; maintains 19 °C below ambient with a tolerance range of between -2.0 and +4.0 °C <ul style="list-style-type: none"> • At a set point of 4 °C with ambient temperature <23 °C and humidity <80%, maintains a sample temperature of 2 to 8 °C. • At ambient temperatures >23°C and humidity <80%, maintains an average sample temperature of 18 °C below ambient, ±3.0 °C. |
| Minimum sample compartment temperature specifications | See the graph that follows this table for the achievable sample compartment temperature and expected variation at various sample temperatures. The graph shows achievable sample compartment temperature and expected variation at various sample temperatures. |
| Recommended locations for temperature sensors | See the diagram that follows this table for the recommended locations for temperature sensors on the sample tray when validating specifications. |
| Temperature accuracy | ±0.5 °C at sensor |
| Temperature stability | ±1.0 °C (at the sensor with sample compartment door closed) |
| Injection needle wash | Integral, active, and programmable |
| Minimum sample required | 3 µL, residual, using total recovery 2-mL vials (zero offset) |

| Item | Specification |
|-----------------------|--|
| Sample carryover - UV | <p data-bbox="537 275 808 302"><0.004% caffeine (UV)</p> <p data-bbox="537 310 727 338">Test conditions:</p> <ul data-bbox="537 365 1421 1142" style="list-style-type: none"> <li data-bbox="537 365 850 392">• Solvent A: 100% water <li data-bbox="537 417 915 445">• Solvent B: 100% acetonitrile <li data-bbox="537 470 1008 497">• Weak wash: 10:90 acetonitrile/water <li data-bbox="537 522 1019 550">• Strong wash: 10:90 acetonitrile/water <li data-bbox="537 575 1252 602">• Column: ACQUITY UPLC BEH C₁₈ 1.7 mm, 2.1 × 50 mm <li data-bbox="537 627 1101 655">• Mobile phase: 90% solvent A:10% solvent B <li data-bbox="537 680 837 707">• Flow rate: 0.6 mL/min <li data-bbox="537 732 1421 842">• Sample: caffeine, at 0.16 mg/mL (standard) and 4 mg/mL (challenge) in 10:90 acetonitrile/water, compared with blanks of 10:90 acetonitrile/water <li data-bbox="537 867 841 894">• Injection volume: 5 µL <li data-bbox="537 919 906 947">• Column temperature: 40 °C <li data-bbox="537 972 1325 1041">• Detection: UV at 273 nm, sampling rate = 20 points/s, filter time constant = normal (0.2 s) <li data-bbox="537 1066 769 1094">• Run time: 2 min <li data-bbox="537 1119 1122 1146">• Data system: Empower or MassLynx software <p data-bbox="537 1171 1421 1274">Basis of calculation: Any peak in the blanks following the challenge sample are compared with the known (0.005%) standard. Carryover peak areas below the standard area are within specification.</p> |

| Item | Specification |
|-----------------------|---|
| Sample carryover - MS | <p data-bbox="537 275 938 302"><0.005% sulphadimethoxine (MS)</p> <p data-bbox="537 310 727 338">Test conditions:</p> <ul data-bbox="537 365 1393 1213" style="list-style-type: none"> <li data-bbox="537 365 1032 392">• Solvent A: water with 0.1% formic acid <li data-bbox="537 417 1094 445">• Solvent B: acetonitrile with 0.1% formic acid <li data-bbox="537 470 992 497">• Weak wash: 5:95 acetonitrile/water <li data-bbox="537 522 1019 550">• Strong wash: 50:50 acetonitrile/water <li data-bbox="537 575 1101 602">• Mobile phase: 80% solvent A:20% solvent B <li data-bbox="537 627 834 655">• Flow rate: 0.3 mL/min <li data-bbox="537 680 1393 785">• Sample: sulphadimethoxine at 5 pg/μL (standard) and 1 μg/μL (challenge) in 10:90 acetonitrile/water +0.1% formic acid, compared with blanks of 10:90 acetonitrile/water +0.1% formic acid <li data-bbox="537 810 841 837">• Injection volume: 5 μL <li data-bbox="537 863 1247 890">• Column: ACQUITY UPLC BEH C₁₈ 1.7 μm, 2.1 × 50 mm <li data-bbox="537 915 906 942">• Column temperature: 40 °C <li data-bbox="537 968 906 995">• Sample temperature: 10 °C <li data-bbox="537 1020 1393 1056">• Detection: MS SIR at 311.3 Da, 0.5 s dwell or MRM at 156.0 to 310.0 <li data-bbox="537 1081 760 1108">• Ion mode: ES+ <li data-bbox="537 1134 769 1161">• Run time: 5 min <li data-bbox="537 1186 1122 1213">• Data system: Empower or MassLynx software <p data-bbox="537 1241 1403 1339">Basis of calculation: Any peaks in the blanks following the challenge sample are compared with the known (0.005%) standard. Carryover peak areas <80% of the standard area are within specification.</p> |

Figure B-1: Recommended temperature sensor locations

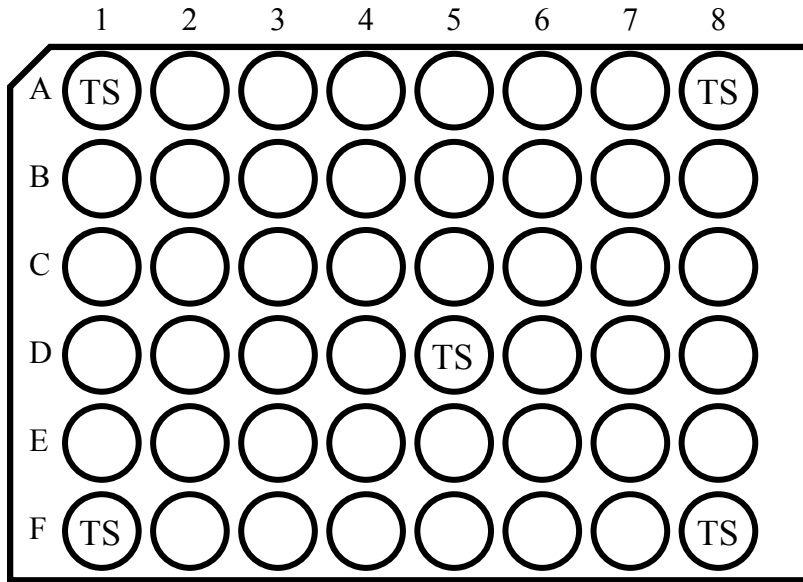

TS Temperature sensor

Figure B-2: Minimum sample compartment temperature specifications

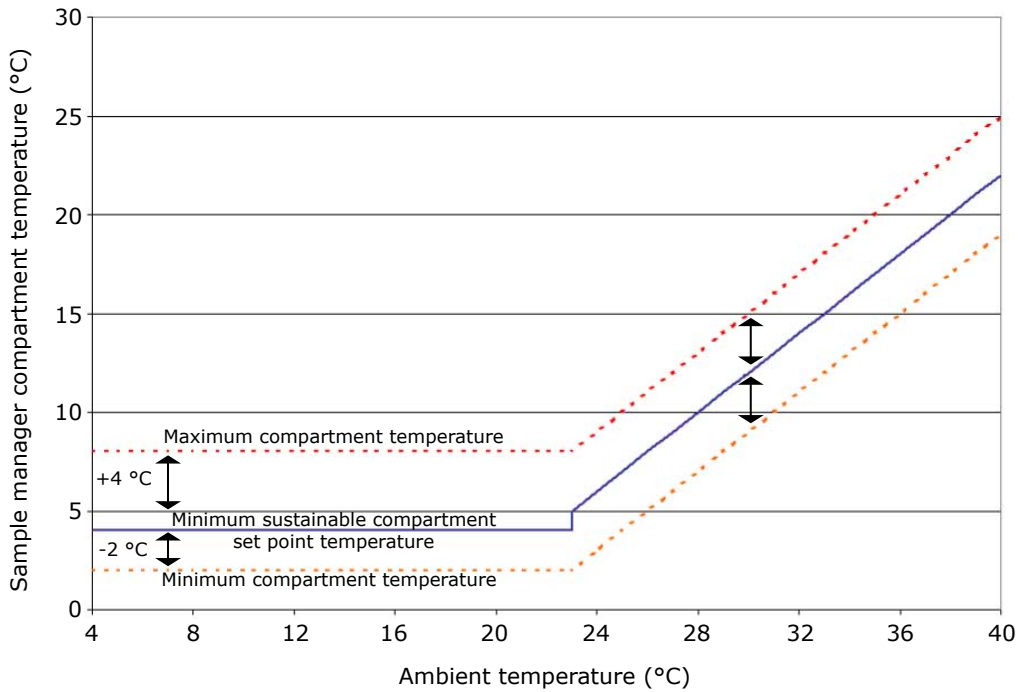

B.6 SM-FTN and bioSM-FTN wetted materials of construction

| Description | Specification |
|-------------|---|
| SM-FTN | 316 stainless steel, DLC, gold-plated stainless steel, PEEK blend, polyimide, PPS |
| bioSM-FTN | DLC, gold-plated stainless steel, MP35N, PEEK blend, polyimide |